

MAKE  
SOMETHING  
WONDERFUL

$$\int_0^{\text{Wonderful}} \text{make}(x)dx = \text{snapmaker}$$

snapmaker

Artisan 3D Printer (Standard 3-in-1 Addons)

# QUICK START GUIDE

Laser Engraving and Cutting

CNC Carving and Cutting

Enclosure

"We are all in the gutter, but some of us are looking at the stars."  
— Oscar Wilde

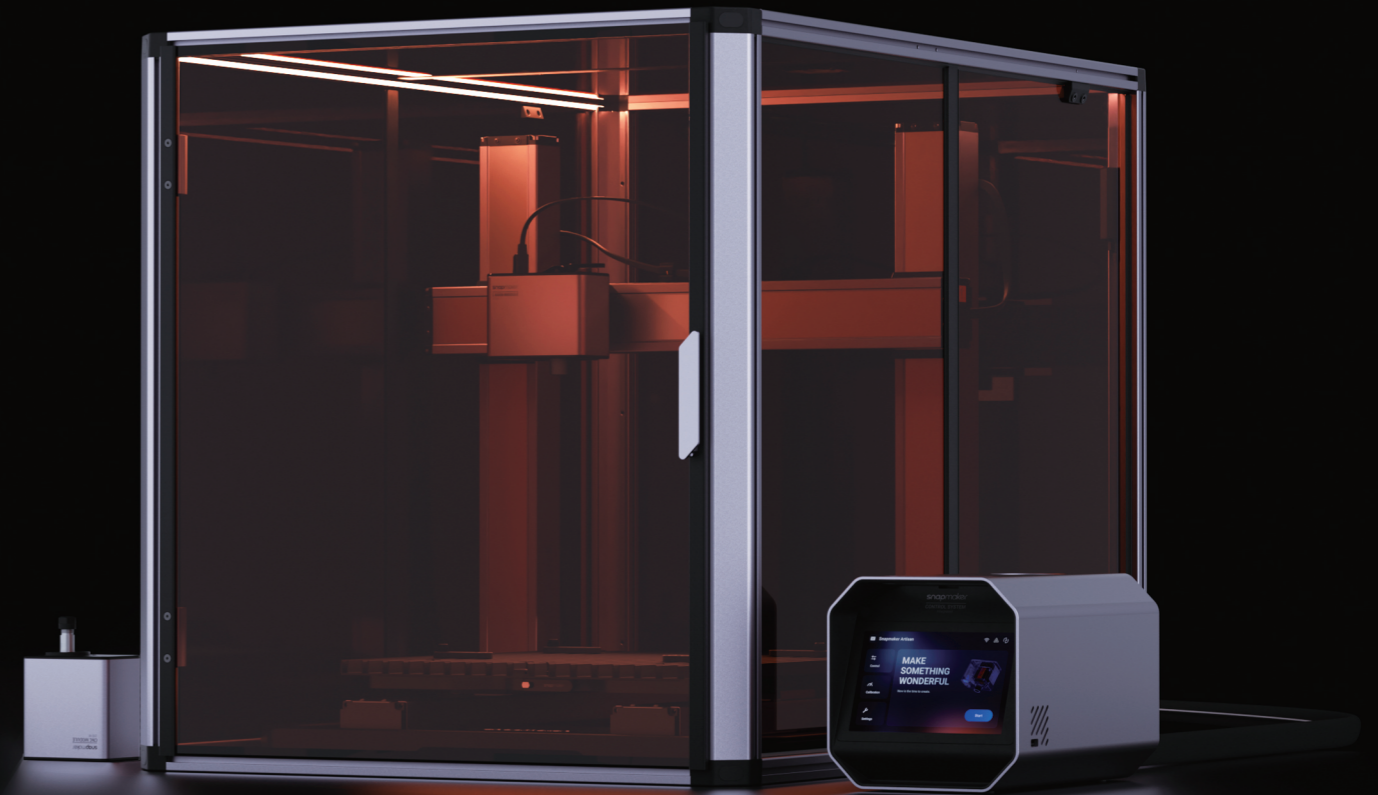

# CONTENTS

- Before You Start ..... 01**
  - 1.1 Disclaimer..... 02
  - 1.2 Intended Use ..... 02
  - 1.3 Safety Information..... 03
  - 1.4 Safety Labels on Your Snapmaker ..... 06
  - 1.5 Specifications ..... 07
  - 1.6 Parts List ..... 08
  - 1.7 Assembly Instructions ..... 10
  - 1.8 Used Symbols..... 11
  - 1.9 About This Guide..... 11
  
- Enclosure Settings ..... 12**
  - 2.1 Enable/Disable Door Detection..... 13
  - 2.2 Turn On/Off LED Strips and the Exhaust Fan..... 15
  
- Laser Engraving and Cutting ..... 16**
  - 3.1 Preparations..... 17
  - 3.2 Getting Started ..... 24
  - 3.3 Maintenance ..... 31
  
- CNC Carving and Cutting ..... 32**
  - 4.1 Preparations..... 33
  - 4.2 Getting Started ..... 39
  - 4.3 Maintenance ..... 49
  
- Resources ..... 52**

# Before You Start



## 1.1 Disclaimer

Make sure that anyone who uses this product knows and understands the contents of the Quick Start Guide. Failure to observe this guide may lead to personal injury, inferior results, or damage to the Snapmaker products.

Snapmaker does not assume responsibility and expressly disclaims liability for any personal injury, inferior results, or damage to the product arising out of or in connection with your improper operations or failure to follow the instructions of the guide.

When using Snapmaker products, you should comply with the following requirements:

- Follow the instructions of this guide, the applicable laws and regulations, and the safety regulations in the assembly, handling, storage, use, maintenance, or disposal of this product.
- Ensure there is no infringement on any third-party intellectual property rights or violation of any applicable laws or regulations when making objects using this product.

The conditions or methods of using Snapmaker products are beyond the control of Snapmaker. For this reason, Snapmaker does not assume responsibility and expressly disclaims liability for any consequences resulting from:

- your improper methods, failure to follow the instructions of this guide or impacts of other uncertain factors when operating this product;
- your infringement on any third-party intellectual property rights or violation of any applicable laws or regulations when making objects using this product;
- personal injury, inferior results, or damage to the product arising out of or in connection with the assembly, handling, storage, use, maintenance, or disposal of this product.

All the Snapmaker filaments and materials are compatible with this product and have been tested for safety. If you use this product with third-party filaments or materials, Snapmaker does not assume responsibility and expressly disclaims liability for any adverse effects from the use or performance of these filaments and materials.

This guide is provided for reference purposes only. We do not warrant the absolute accuracy or completeness of the information provided by this guide. No part of this guide may be reproduced, edited, or revised by any means without the prior written permission of Snapmaker. We reserve the right to modify or revise this guide in our sole discretion at any time without notice. You can download the most up-to-date version of this guide at our Support Center (<https://support.snapmaker.com/>): select **Snapmaker Artisan** > **Quick Start Guide**.

## 1.2 Intended Use

Snapmaker modular 3D printers are intended for use under the guidelines provided in this guide. When making objects using Snapmaker modular 3D printers, users remain responsible for qualifying and validating the application of the created object for its intended use, especially for applications in strictly regulated areas like medical devices and aeronautics.

## 1.3 Safety Information

### 1.3.1 General Safety Information

- Follow the applicable local laws and regulations in the operation and application of this product.
- Follow the instructions of the guide to use and maintain this product for safety purposes.
- Do not expose this machine to rain or wet conditions.
- Always operate this machine indoors on a solid horizontal table or workbench.
- Minors are only allowed to use this product under adult supervision and assistance.
- Ensure that bystanders also read and understand all the safety notes of this product and keep bystanders away while operating this product for safety purposes.
- Stay alert, watch what you are doing, and pay attention to the surrounding environment when operating this product.
- Do not use this product while you are tired or under the influence of drugs, alcohol, or medication.
- Do not reach inside the product or touch the moving parts while the product is still in operation.
- Do not leave the product unattended while it is still powered on.
- Always unplug the power cable from the electrical outlet before performing maintenance or modifications.

**Turn off the machine immediately and stop using this product if any of the following occurs:**

- You smell burning in this product at any point.
- You see any damage to the interior components of this product.
- The machine stops working unexpectedly.
- Unusual lights, sparks, or sounds come out of this product which has never occurred previously.

### 1.3.2 Laser Safety Information

- The 10W Laser Module is a Class 4 laser product. When you use the laser module correctly and in combination with the Enclosure as required, the overall laser classification of this product is Class 1.
- You should operate this product only if you have sufficient knowledge of (i) the physical properties of laser radiation, (ii) Laser Hazard Classes and associated health implications, and (iii) safety measures.
- The 10W Laser Module must be used together with the Enclosure. Please follow this guide to assemble and use the Enclosure. During laser processes, the Enclosure helps to prevent the risk of laser leakage by effectively filtering laser radiation and pausing the ongoing job if the Enclosure door is opened.
- An air purifier should be used depending on the type and constituent of the materials you are going to use, as some materials may release hazardous and toxic fumes when laser engraved or cut. Ensure that the air purifier you choose is effective enough to protect human health and prevent environmental pollution.
- Do not directly look at or touch the laser aperture or expose yourself to the laser beam during operation.
- Ensure that there is no reflective material within the work area during operation, as it may cause scattered radiation and pose safety risks.
- Ensure that there is no flammable and explosive material within the work area or around the machine during operation, as it may cause a fire.
- The 10W Laser Module mustn't be used with the 3D printing platform and the CNC carving and cutting platform (allowed only in the 4-axis machining scenario, for the Rotary Module can only be attached to the CNC platform). Otherwise, it might damage the mismatched work platform, cause a fire, or pose other risks.

### 1.3.3 CNC Safety Information

- Users of the CNC Module should be at least 18 years old and have relevant experience.
- Use the CNC Module together with the Enclosure.

- All the users and bystanders must wear the CNC safety goggles during operation.
- Before a CNC process, make sure to securely clamp the material.
- During a CNC process, never attempt to hold the workpiece with your hands.
- If the bit or workpiece becomes jammed or bogged down, turn off the machine immediately. Wait for all the moving parts to stop, unplug the cable, and then work to free the jammed material.
- Do not touch the bit or the collet right after use, as doing so could cause burn injuries.
- The toxic substances contained in some materials might be released in CNC carving and cutting processes. To reduce the harm, use the CNC Module with air purifying devices or in a well-ventilated environment and take safety precautions, such as wearing a mask.

### 1.3.4 Enclosure Safety Information

- To move the Enclosure or the machine, you must first separate the machine and the Enclosure.
- Do not scrape, bend or break the acrylic panels, profiles, or the door handle. Doing so can compromise protection, cause permanent damage to the Enclosure, or even cause personal injuries.
- Do not place the Integrated Controller inside the Enclosure when using this product.
- Do not place objects that weigh more than 7 kg on top of the Enclosure. Otherwise, the top panel will be damaged.
- Do not put any objects or body parts into the exhaust fan when the fan is operating.
- Keep the cables away from the exhaust fan blades to avoid damaging the exhaust fan or other parts of this product.

### 1.3.5 Precautions and Emergency Measures

#### Laser Engraving and Cutting

##### Eye Injury from Laser

If your eyes are exposed to direct or scattered laser beams, take the following measures immediately:

1. Grab a nearby thick and opaque object to block the laser beam, preventing further exposure to laser.
2. Shut down the laser engraver and cutter immediately.
3. If an eye injury is suspected, a medical examination by a qualified specialist needs to be carried out as soon as possible.
4. If an eye injury is apparent, call the local hospital for emergency help.

##### Skin Injury from Laser

Lasers can harm the skin via photochemical or thermal burns. When you suffer from skin burns caused by lasers, take the following steps as an emergency response:

1. If it is a major burn, call for emergency medical care before you take the subsequent steps.
2. Remove any clothing or jewellery near the burnt area of skin, but do not move anything that's stuck to the skin.
3. Hold the burn under cool or lukewarm running water until the pain subsides. Use cool, wet compresses if running water isn't available.
4. After the burnt area has been cooled, use painkillers such as paracetamol or ibuprofen to treat any pain.
5. Use a sterile, non-adhesive bandage or clean cloth to loosely bandage the burn.

##### Exposure to Gases or Fumes

The heating which occurs during laser cutting or engraving can cause charring, pyrolysis, or even combustion of the material being worked on and generate gases or fumes.

##### - Airway Irritation

Gases and fumes may irritate the airways and potentially be extremely dangerous. If airway irritation occurs,

take the following steps as an emergency response:

1. Expose the casualty to fresh air.
2. Call for medical help.
3. If the person is unresponsive, not breathing, or not breathing normally, perform CPR until the person begins breathing or emergency help arrives.

##### - Eye Irritation

Being exposed to gases or fumes may cause the eyes to become red and watery, and induce a grainy feeling.

Should eye irritation occur, take the following steps as an emergency response:

1. Rinse the affected eyes with room temperature water for 10 to 20 minutes to relieve symptoms. Sterile water or sterile normal saline solution (0.9%) from sealed disposable containers can be used. Press the eyelids wide open and keep them apart while rinsing.
2. Transfer the casualty to the hospital as soon as possible for an eye examination and further treatment.

##### Fire

Laser engraving and cutting can present a significant fire hazard due to the extremely high temperature caused by the laser beam. If a fire occurs, take the following steps as an emergency response:

1. If the fire is small in size (no larger than a small trash can), you can use an extinguisher to put it out. Before dousing the flame, remember to cut electrical power.
2. If the fire is large, call for help immediately by pulling the nearest alarm and do not attempt to fight it yourself.
3. Move quickly to the nearest accessible exit. Notify and assist others in evacuating along the way. Do not use the elevators.
4. Contain the fire and the smoke by closing all doors leading into and surrounding the fire area. Do not lock them.
5. After a total and immediate evacuation, call medical attention for the casualty.

#### CNC Carving and Cutting

##### Injury from Sharp Objects

If you get injured from sharp objects, take the following steps as an emergency response:

1. Apply pressure to the wound with a clean cloth for a few minutes until the bleeding stops. If the bleeding won't stop or other tissues are severely injured, seek medical help immediately.
2. Use sterilized tweezers to remove dirt and debris around the wound. If the debris penetrates deep into your skin, seek medical help immediately.
3. Gently rinse the wound, and wipe away the residual water with a clean cloth.
4. Apply antiseptic cream on the wound to prevent infection. If the wound is infected, seek medical help immediately.
5. Use a bandage to protect the wound from further exposure to dirt and bacteria.

**Any injuries to vulnerable parts, like faces, eyes, and arteries, require immediate medical treatment.**





##### Inhalation of Dirt and Sawdust

CNC carving and cutting produce dust and sawdust, which might irritate your respiratory system. Generally, we recommend you use air-purifying devices and wear protective masks when carving and cutting. If respiratory irritation occurs, immediately expose the casualty to fresh air and seek medical help.

##### Inhalation of Scorched Smell

Sometimes, CNC carving and cutting can emit a scorched smell, which might irritate your respiratory system. Generally, we recommend you carve and cut with air-purifying devices or in a well-ventilated environment. If respiratory irritation occurs, immediately expose the casualty to fresh air and seek medical help.

# 1.4 Safety Labels on Your Snapmaker

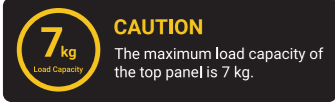
Label	Warning	Location
	Take care to avoid injury from sharp objects (e.g., CNC bits).	On the 200W CNC Module
	Laser radiation is emitted from this aperture. Do not touch the aperture, and avoid eye and skin exposure to direct or scattered radiation.	On the 10W Laser Module
	Class 4 laser product. Avoid eye and skin exposure to direct or scattered radiation.	On the 10W Laser Module
	Class 1 laser product. Avoid eye and skin exposure to direct or scattered radiation when the interlocks are defeated.	On the Enclosure Door
	Do not place objects that weigh more than 7 kg on this surface.	On the top panel of the Enclosure

\* The photographs in this guide take the safety label required in the EU region as an example.  
\* The same label on different locations may vary in color or texture.

# 1.5 Specifications

Enclosure			
Minimum Footprint (W × D × H)	1035 mm × 1690 mm × 705 mm		
Material	Profile: Aluminum alloy	Panel: Acrylic sheet	
Laser Engraving & Cutting			
Work Area (X × Y)	400 mm × 400 mm	Power	10 W
Laser Type	450 nm–460 nm Semiconductor	Laser Classification (within Enclosure)	Class 1
Max. Engraving Speed	100 mm/s	Max. Cutting Depth (Paulownia)	8 mm
Operating Temp.	0°C–35°C	Laser Spot Dimensions	0.05 mm × 0.2 mm
Supported Materials for Engraving	Basswood, Paulownia, Pinewood, Plywood, Beech, Walnut, Bamboo, MDF, Painted Metal, Tinplate, Stainless Steel, Anodized Aluminum, Dark Glass, Slate, Ceramics, Jade, Marble, Shale, Leather, Fabric, Canvas, Corrugated Paper, Cardboard, Plastic, Dark Acrylic (Blue excluded)		
Supported Materials for Cutting	Basswood, Paulownia, Pinewood, Plywood, Beech, Walnut, Bamboo, MDF, Leather, Fabric, Canvas, Corrugated Paper, Cardboard, Plastic, Dark Acrylic (Blue excluded)		
Bluetooth (10W Laser Module)	Protocol: BT 2.1 + EDR/3.0 Frequency Range: 2402 MHz–2480 MHz Transmitter Power (EIRP): < 11.35 dBm (USA & Canada), < 9.23 dBm (EU)		
CNC Carving & Cutting		Snapmaker Luban	
Work Area(X × Y)	400 mm × 400 mm	Supported OS	Windows, macOS, Linux
Power	200 W	Supported File Formats	3D Printing: .stl, .obj Laser Engraving and Cutting: .stl, .svg, .png, .jpg, .jpeg, .bmp, .dxf
Max. Spindle Speed	18,000 RPM	Generated File Formats	3D Printing: .gcode Laser Engraving and Cutting: .nc CNC Carving and Cutting: .cnc
Max. Work Speed <sup>1</sup>	Beech: 50 mm/s Acrylic: 33 mm/s		
Max. Stepdown	Beech: 2 mm Acrylic: 1 mm		
Shank Diameter	0.5 mm–6.35 mm		
Supported Materials	Hardwood (Beech, Walnut), Softwood, HDF, MDF, Plywood, Jade, Carbon Fiber, Acrylic, Epoxy Tooling Board, PCB		

[1] The data is obtained by cutting Beech with the 3.175 mm flat end mill (double-flute) and Acrylic with the 3.175 mm flat end mill (single-flute). The cutting speed might vary depending on the CNC bits and materials used.

\* The specifications above are subject to change as we improve the product.

# 1.6 Parts List

- Quick Start Guide x 1
- Profile Connector x 6
- Short Beam x 1
- Short Beam (with profile connectors) x 1
- Short Beam (with screw holes) x 2
- Long Beam x 2
- Long Beam (with tube holder) x 2
- Middle Column x 2
- Middle Beam x 1

- Side Panel x 2
- Door Panel x 1
- Side Panel (with tube holder cutout) x 2
- Top Panel x 2
- Back Panel x 1

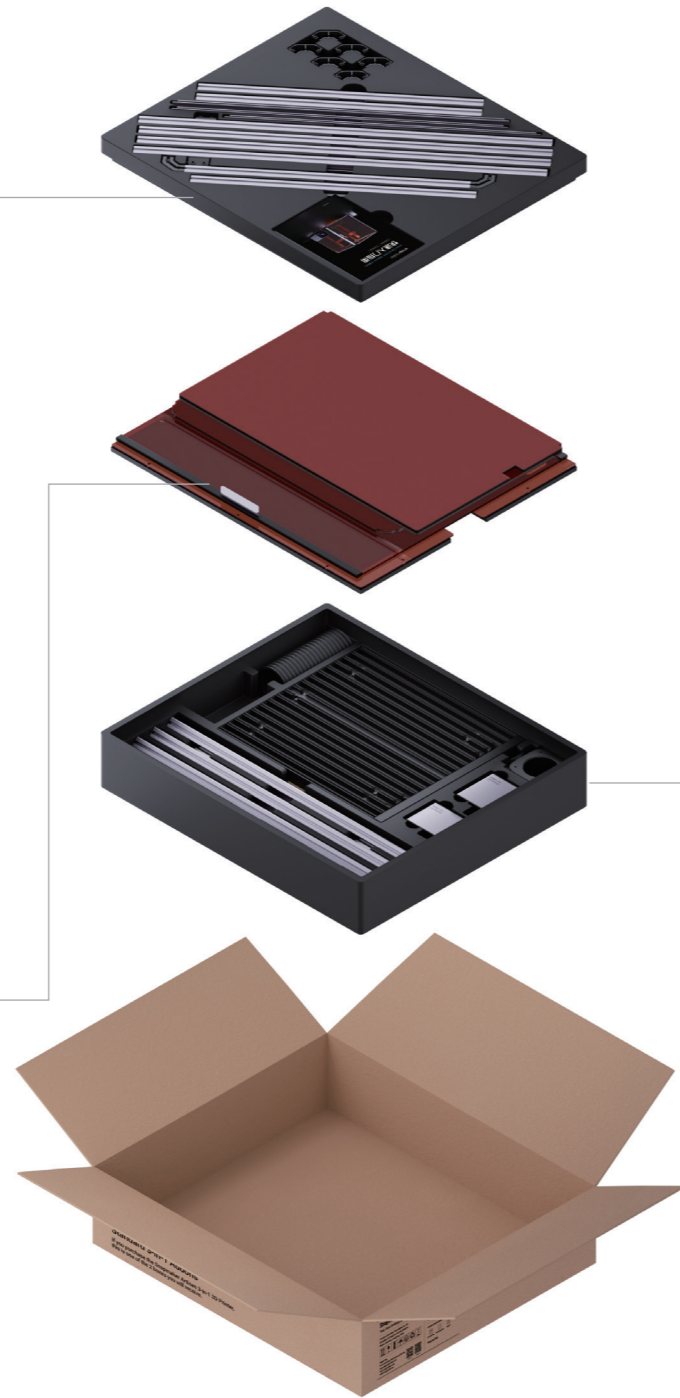

- Column-1 (with hinge) x 1
- Column-2 (with hall switch) x 1
- Column-3 (with Enclosure converter) x 1
- Column-4 x 1
- CNC Carving and Cutting Platform x 1
- Laser Engraving and Cutting Platform x 1
- Sealing Plug x 8
- Filament Tube Clip x 2
- 10W Laser Module x 1
- 200W CNC Module x 1
- ER11 Collet & ER11 Nut x 1
- Basswood Sheet x 1
- HDF Sheet x 1
- Calibration Target x 1
- Cord Collecting Strip x 1
- Filament Tube x 2
- Hose Connector x 1
- Exhaust Fan x 1
- Hose x 1
- CNC Safety Goggles x 1
- Cable Pass-through Fixture x 1
- Base Fixture (upper) x 2
- Base Fixture (lower) x 2
- Star Knob x 4
- Arched Fixture x 4
- Fixture Accessory x 4
- Hose Clamp x 1
- Straight Groove V-bit (double-flute) x 1
- Flat End Mill (single-flute) x 1
- Flat End Mill (double-flute) x 1
- 14mm Open-end Wrench x 1
- 17mm Open-end Wrench x 1
- M4 x 12 Flat Head Screw x 5
- M5 x 12 Screw x 20
- M4 x 20 Screw x 7
- M5 x 16 Low Head Cap Screw x 12
- M5 x 30 Screw x 20
- M4 Wing Nut x 5
- Laser Material Fixture x 4
- M6 x 16 Screw x 8
- L Bracket x 1
- M4 x 12 Low Head Cap Screw x 2
- M4 x 35 Screw x 5
- Laser Lens Protector x 1
- Enclosure Cable x 1
- Sealing Strip (wide) x 1
- Sealing Strip (narrow) x 1
- M4 x 60 Screw x 4
- Cotton Swab x 5

# 1.7 Assembly Instructions

## 1.7.1 Video Tutorial

Please go to our YouTube channel @Snapmaker to watch the video tutorial and complete the assembly.

To avoid missing any important details, **please play the videos on a device with a large screen.**

To minimize the assembly time and effort, we recommend that you assemble in the following order:

**Machine > Enclosure > 3D Printer/Laser Engraver and Cutter/CNC Carver and Cutter**



## 1.7.2 Tips & Notes

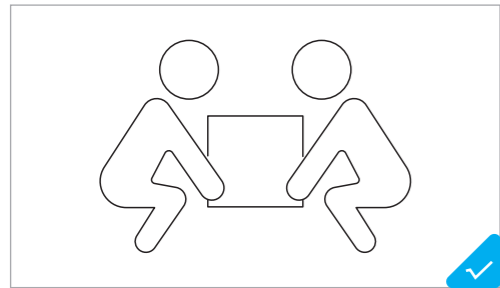

At least two people are required to assemble and lift the machine and the Enclosure.

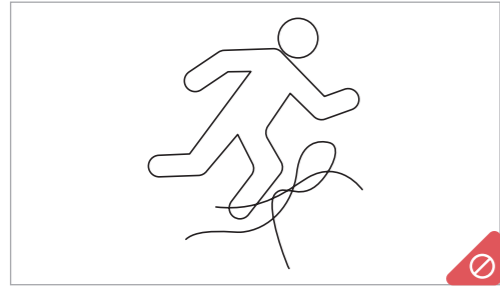

Collect and sort the cables in time lest anyone should trip over them.

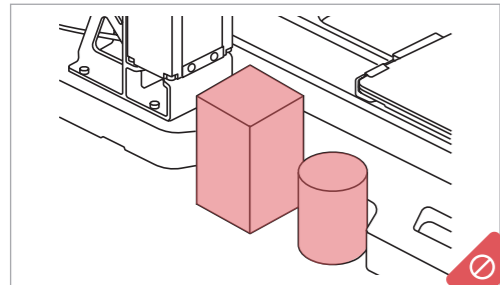

Do NOT place any object near the left or the right side of the base plate to avoid interfering with the movement of the Linear Modules and the work platforms.

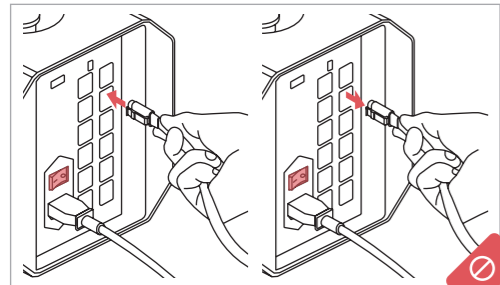

Do NOT plug or unplug any cables when the machine is powered on.

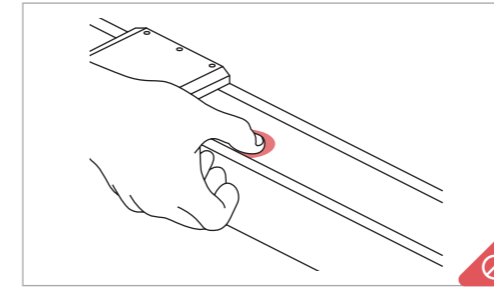

Do NOT press the steel strip. If the steel strip comes out, flatten it by hand from either end of the linear module to the other end.

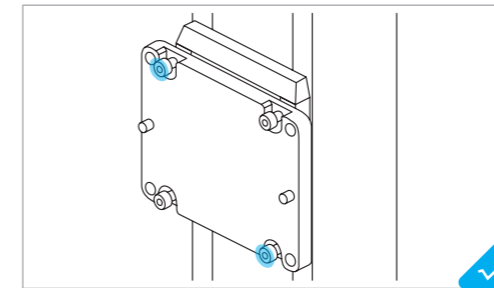

To install multiple screws in one step:

1. Pre-tighten the screws at the outermost corner;
2. Pre-tighten the remaining screws;
3. Tighten all the screws in the pre-tightening order.

\* Pre-tighten: To screw the screw into the hole, yet not fully tighten it.

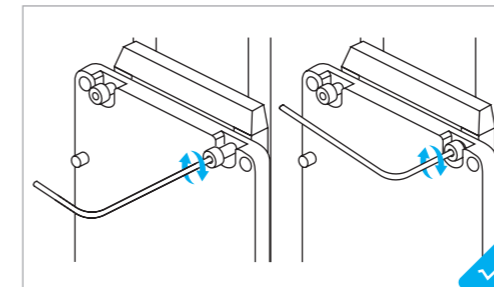

To install screws with the provided hex key:

1. Screw the screw into the hole with the long handle;
2. Tighten the screw with the short handle.

## 1.8 Used Symbols



**WARNING**

Failure to observe this instruction may lead to damage to the product or personal injury.



**CAUTION**

Details you should pay attention to when using the printer.



**TIPS**

Provides convenient operations or extra choices.

## 1.9 About This Guide

This Quick Start Guide is intended to guide you through the first-time operation of Laser engraving and cutting, CNC carving and cutting, and familiarize you with the Enclosure settings with concise instructions and graphics. The workflows described in this guide are what we consider to be the most convenient ones for you to quickly get started. For other workflows and more information, refer to our online User Manual in Snapmaker Wiki (<https://wiki.snapmaker.com>).

# Enclosure Settings



## 2.1 Enable/Disable Door Detection

The column-2 of the Enclosure features a hall switch to detect whether the door is opened or closed in real time.



You can tap **Settings** > **Enclosure** to enable or disable Door Detection during a 3D printing or CNC process. During a laser process, Door Detection is enabled by default and cannot be disabled.

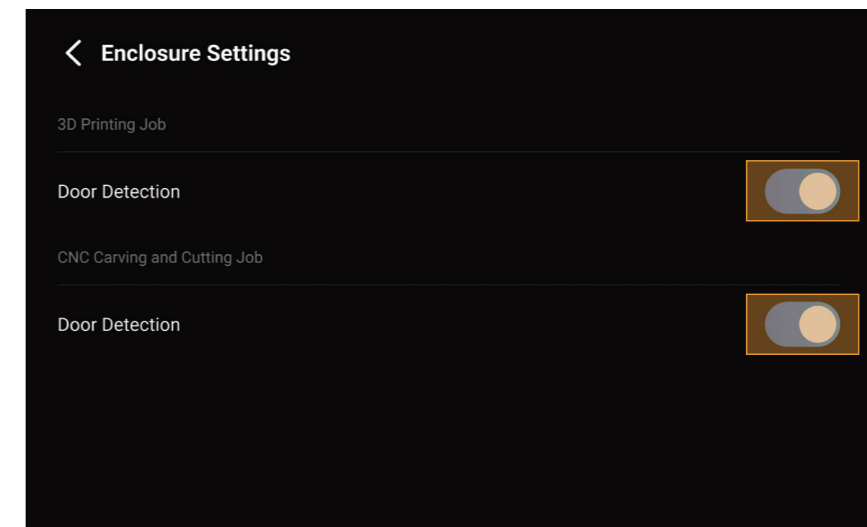



After Door Detection is enabled, the machine will stop operating or end the calibration process immediately whenever the hall switch has detected that the door is opened. To resume operations, you need to close the door first, and then tap  on the Touchscreen to continue the job or restart the calibration process.

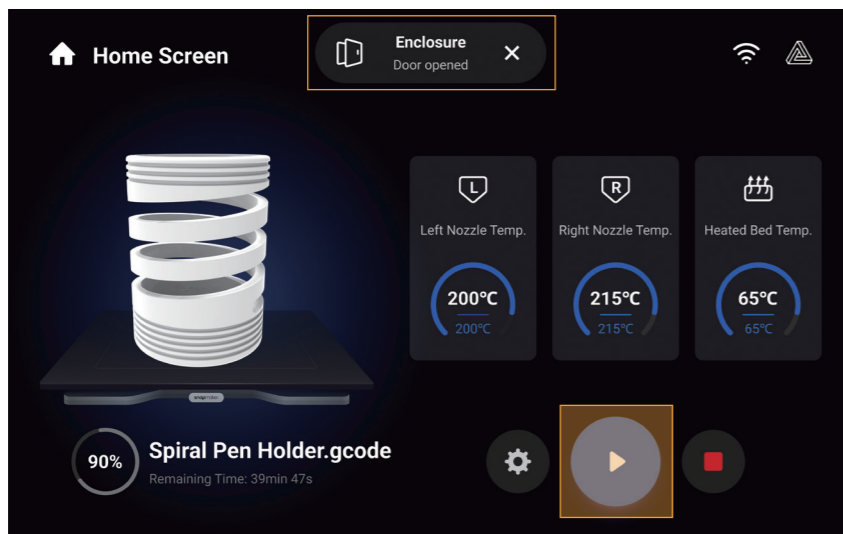
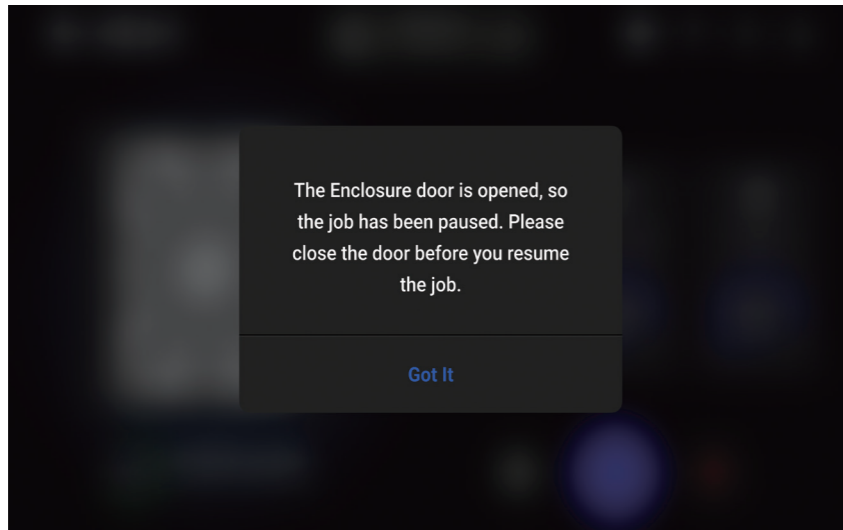

If you need to open the door frequently and do not want the ongoing 3D printing or CNC process to be paused as the door opens, you can disable Door Detection before starting a 3D printing or CNC job.





Whether Door Detection is enabled or not, you must wear the CNC safety goggles before opening the door during a CNC process.



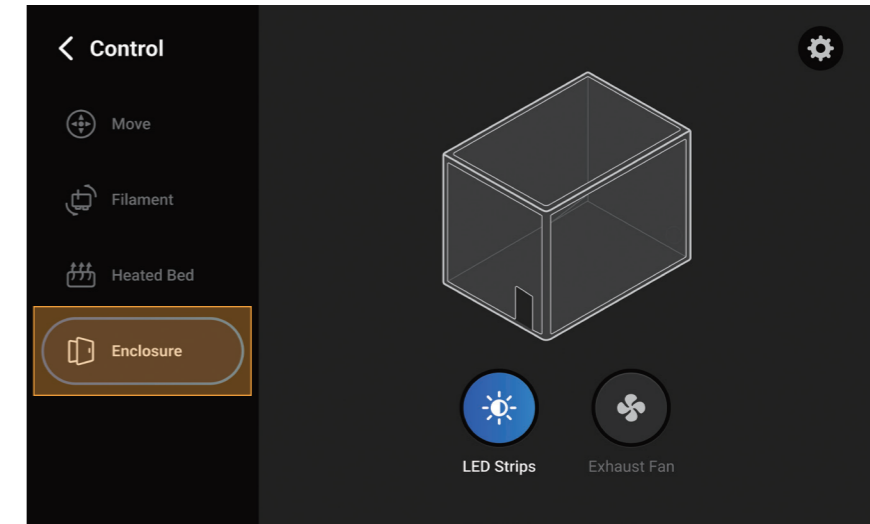

## 2.2 Turn On/Off LED Strips and the Exhaust Fan

You can tap **Control** > **Enclosure** to turn on or off the LED strips and the exhaust fan.





You can also tap  to adjust the settings of the LED strips and the exhaust fan during a 3D printing, laser, or CNC process.





For different scenarios, we recommend turning on or off the LED strips and the exhaust fan as shown in the table:

Scenario		LED	Fan
3D Printing	PLA, Breakaway Support for PLA, TPU90, TPU95, High Flow TPU95, TPU-Foam, PVA	O	O
	ABS, PETG, ASA, HIPS, CoPA, PA12-CF, PA6-CF, PA6-GF	O	×
Laser Engraving and Cutting		O	O
CNC Carving and Cutting		O	×

\*O = On    × = Off



Some filaments (such as ABS) may give off odors or fumes during a 3D printing process, while turning on the exhaust fan may affect the printing temperature and therefore impair the print quality. In this case, you can turn on the exhaust fan after printing. To protect your health and prevent environmental pollution, we recommend using Snapmaker Air Purifier or other air purifying devices during such a 3D printing process.

# Laser Engraving and Cutting



## 3.1 Preparations

### 3.1.1 Set Up the Machine

1. Turn on the power switch on the back of the Integrated Controller.



To restart your machine, wait for at least 5 seconds after power-off.

2. Follow the on-screen instructions to set up the machine: Read the **Terms and Conditions** > Choose the language > Name the machine > Connect to a Wi-Fi network.

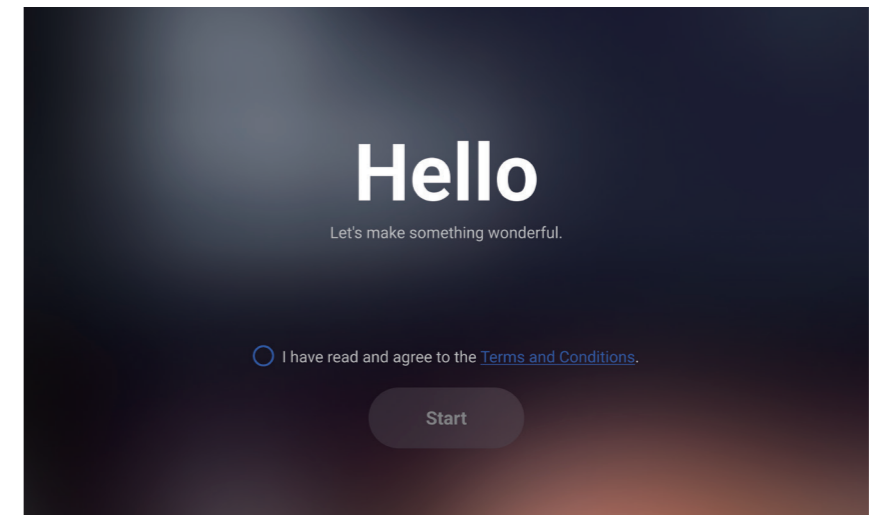

This initial setup wizard appears only the first time you turn on the machine. To change these settings later, tap **Settings** on the Home Screen and select **Wi-Fi**, **Language**, or **About Machine**.

## 3.1.2 Calibrate the 10W Laser Module

For the first-time use of the laser function, the Touchscreen will walk you through the necessary calibrations so that the 10W Laser Module can work properly.

The laser calibration wizard consists of two processes: Thickness Measurement Calibration and Camera Calibration. Before you start the calibration, we recommend that you read this section to learn about each process.

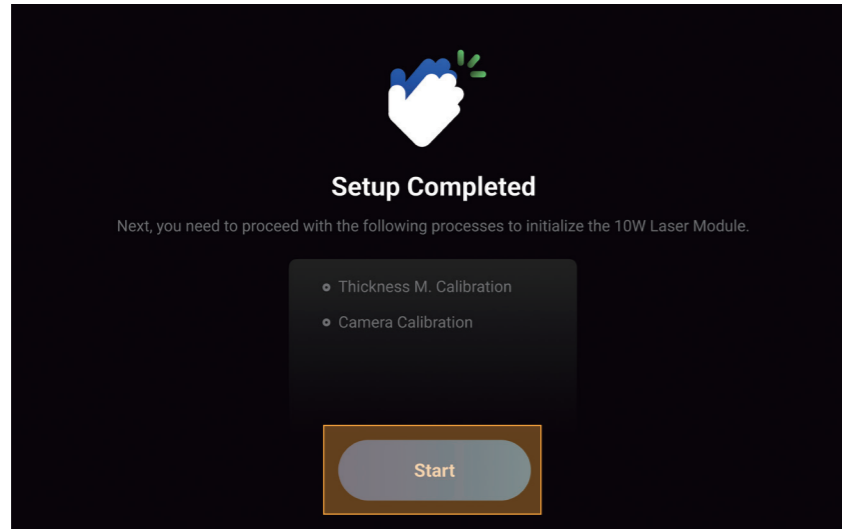

This calibration wizard appears only the first time you use the 10W Laser Module. To redo the calibrations later, tap **Calibration** on the Home Screen and select the corresponding process.

### 1. Thickness Measurement Calibration

#### Brief Introduction

The 10W Laser Module features a thickness measurement system that uses the triangulation technique. The system includes a red laser emitter that projects a red dot on the material surface and a camera that captures the red dot image to calculate the material thickness.

#### How It Works

The Thickness Measurement Calibration adjusts the parameters in the thickness measurement system to ensure accuracy. In this process, a laser calibration plate with known thickness is first used to help the machine determine the height of the laser engraving and cutting platform and then as a measured object to calibrate the system parameters.

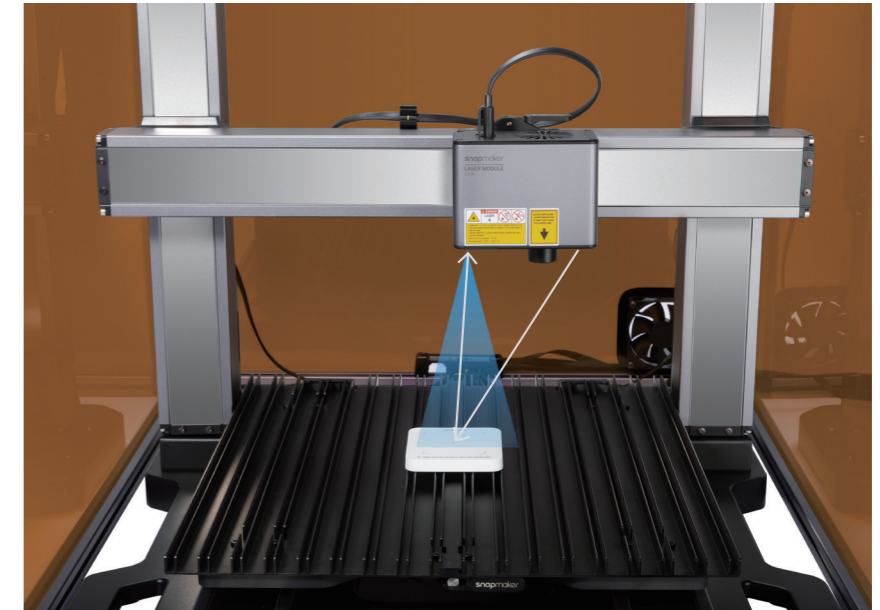

Before you tap **Start**, ensure that the Enclosure door has been closed and then enter the Laser Password on the Touchscreen.

The initial password is the verification code of the machine, which you can find at the bottom of the Integrated Controller.



If you have initialized the 3D printing or the CNC function, you can also check the verification code on the Touchscreen:

- Turn off the machine, and replace the 10W Laser Module with the 3D Printing Module or CNC Module.
- Restart the machine, and tap **Settings > About Machine** on the Touchscreen to check the verification code.



The red laser emitter is a Class 2 laser product. Do NOT look directly into its aperture when the laser beam is being emitted.



Every time after you have reassembled the module or machine, you need to redo the Thickness Measurement Calibration.

## 2. Camera Calibration

### Brief Introduction

The 10W Laser Module contains a wide-angle HD camera to capture the image of the work area, generating a background to edit the laser engraving and cutting objects.

### How It Works

Camera Calibration adjusts the scale of the captured image to display a proper view of the work platform after Camera Capture. During this process, the machine will engrave a square on a piece of blank paper and capture its image to calibrate the camera.

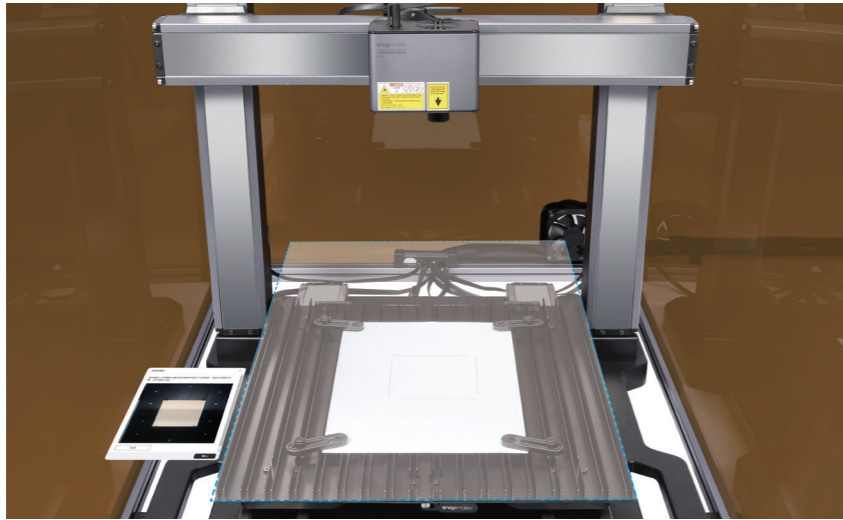

Every time after you have reassembled the module or machine, you need to redo the Camera Calibration.

You can use the provided laser material fixtures to secure the paper.

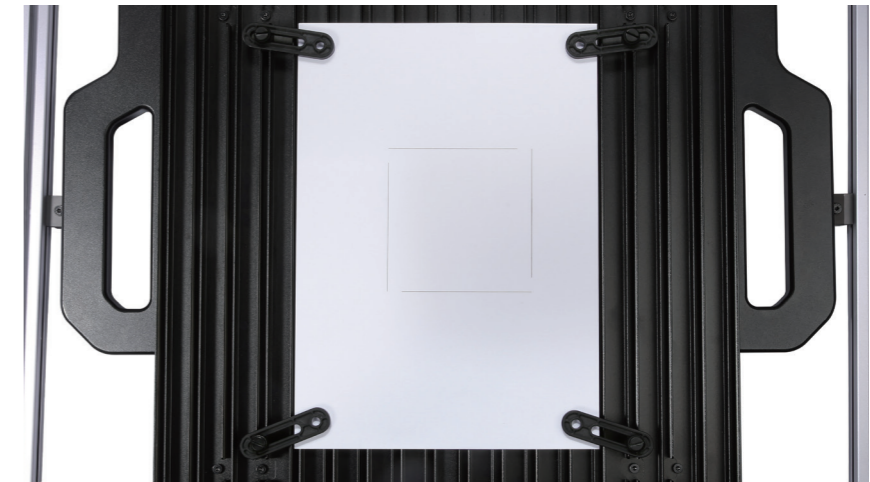

### 3.1.3 Fasten the Material

Place the provided basswood sheet on the laser engraving and cutting platform, use four fixtures to lock its position as illustrated, and use two screws to secure each fixture.

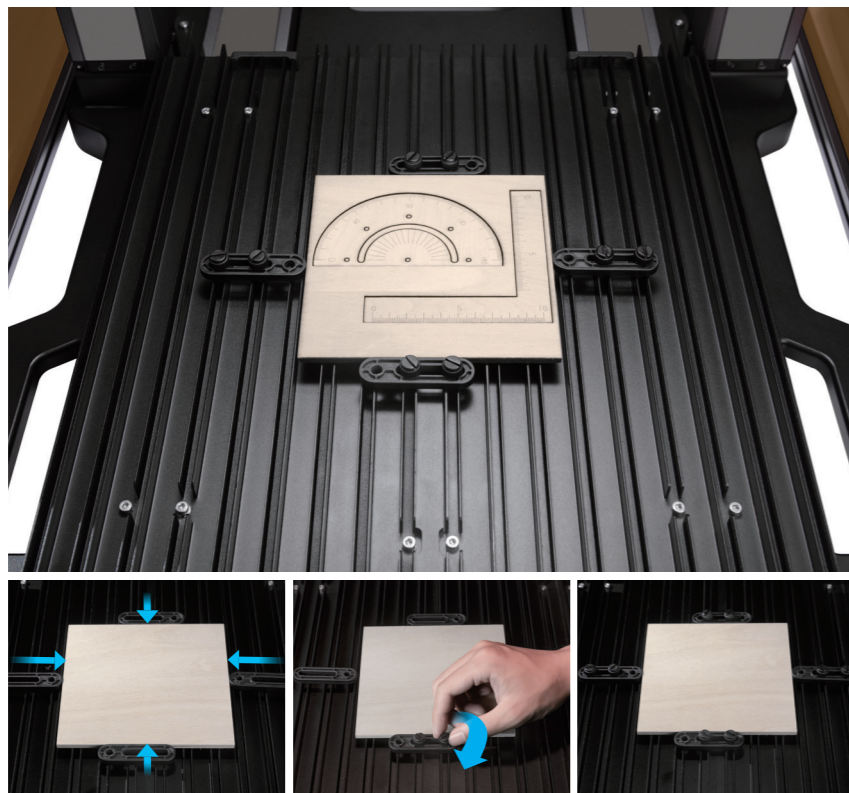

Ensure that the fastening tools will not collide with any parts of the machine.



For ease of operation, you can first detach the laser engraving and cutting platform from the machine, fasten the material on the platform, and install the platform back onto the machine.

You can also put a fixture on each corner of the material and tighten the screws to secure the material. This method applies only to materials with less than 8 mm thickness. You can also fasten the materials with other tools like tape.

**But note: Ensure that the fixtures will not overlap with the engraving and cutting area.**



## Congrats!

You are now ready to engrave and cut.

## 3.2 Getting Started

### 3.2.1 Install Snapmaker Luban

1. On the Snapmaker official website, click **Software** in the navigation bar. Then, download and install our tailor-made software Snapmaker Luban (hereafter Luban).

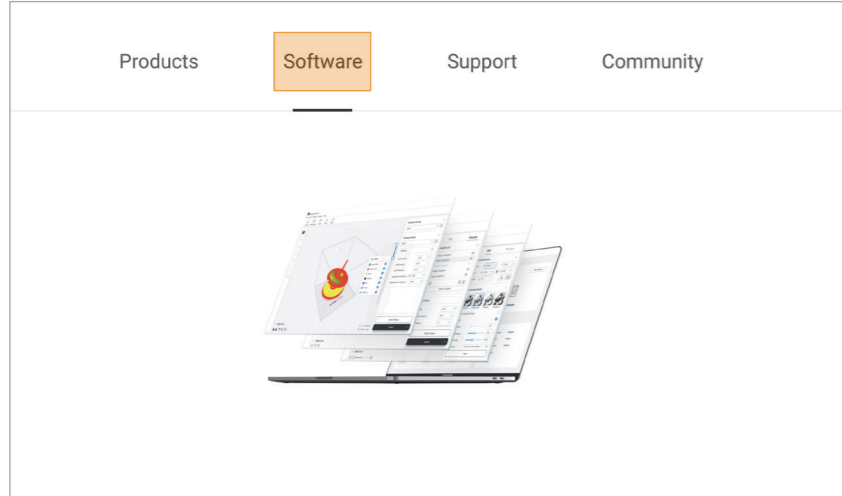

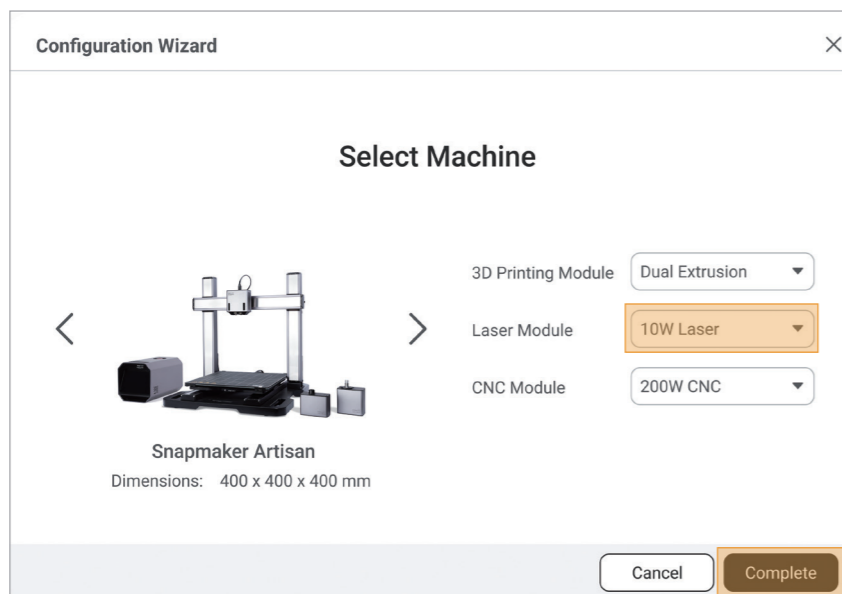

2. Launch Luban, select the language, machine model, and module type, and then click **Complete** to save the settings.



To change these settings later, click **Settings > Preferences** in the menu bar.

3. Ensure that your computer and machine are connected to the same Wi-Fi network, and take the following steps to connect Luban with your machine:

- On the Home page of Luban, click  to enter **Workspace**;
- On the **Connection** panel at the top left corner, click **Wi-Fi**;
- Click , select your machine from the drop-down list, and click **Connect**;
- Tap **Yes** on the Touchscreen to allow the connection.

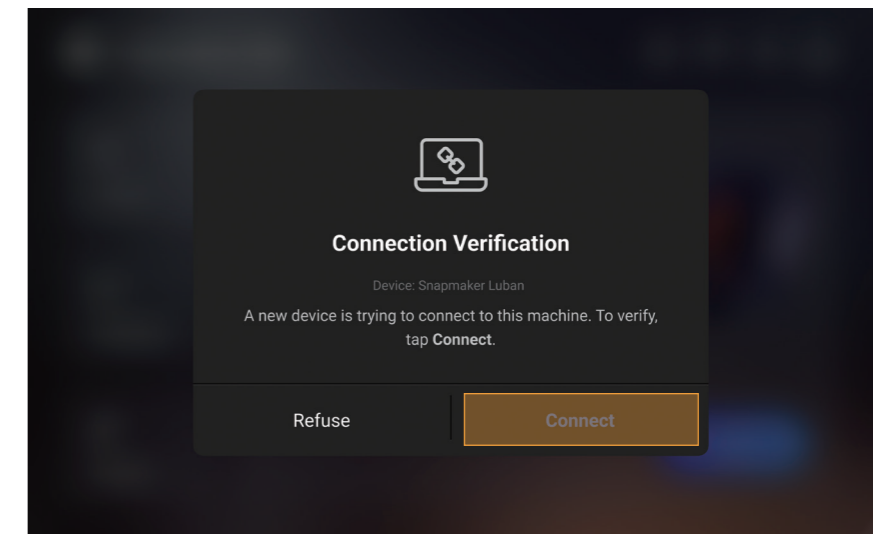
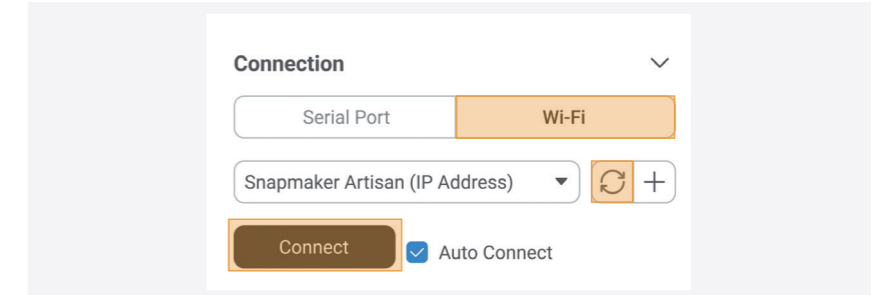
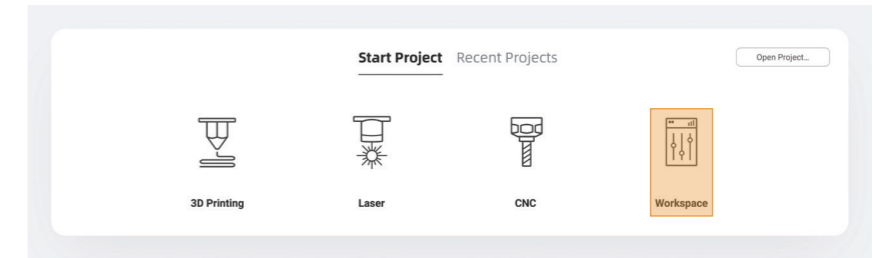

You can also click **+** and enter the IP address of your machine to manually connect it with Luban. To check the IP address, tap **Settings > About Machine** on the Touchscreen.

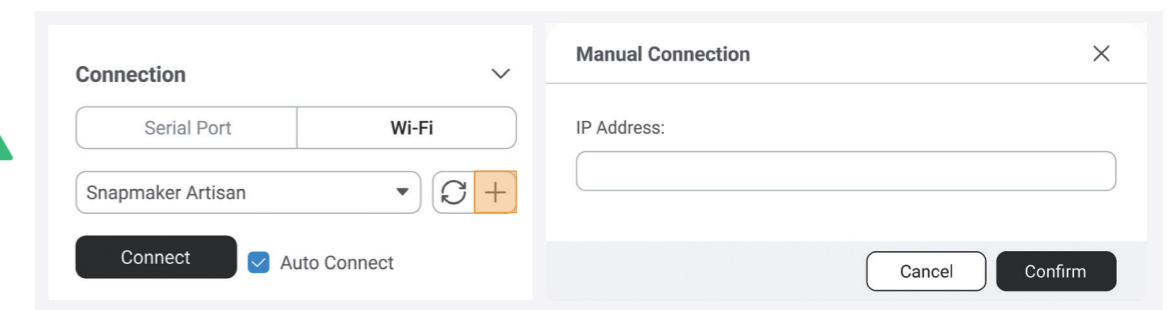

### 3.2.2 Generate the G-code File

1. At the top-left corner of **Workspace**, click **Back** to return to the Home page. Then, click **Laser > 3-axis** to enter the **Laser G-code Generator**.

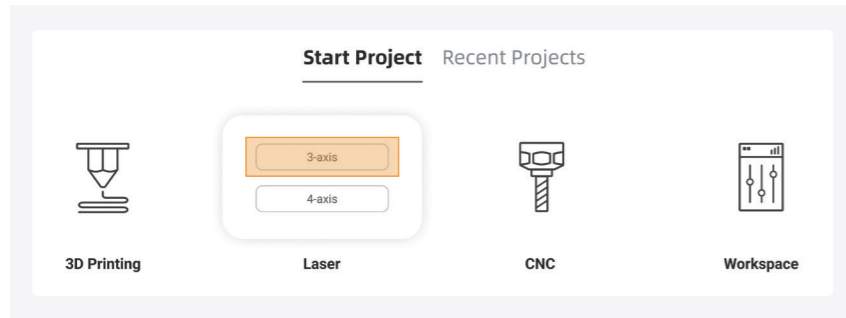

2. Follow the Beginner's Guide to get familiar with the basic operations. During this process, Luban will automatically load the test model and generate the G-code file.

If the Beginner's Guide does not pop up or quits unexpectedly, you can click **Help > Beginner's Guide** in the menu bar.

You can also click to import your own files and configure the parameters.

3. In the menu bar, click **Camera Capture > Add Background > Normal Mode > Start**. The machine will take a photo of the work area and use it as the background for the object to be engraved or cut. After the photo is captured, click **Confirm**.

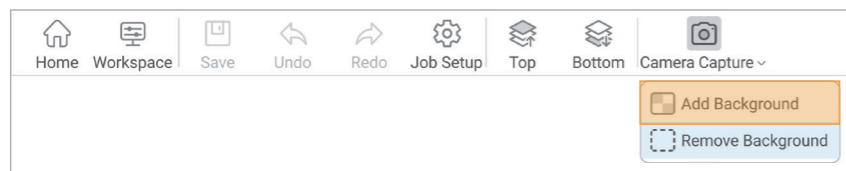

If the captured image is twisted out of shape, click **Calibrate** and follow Luban's instructions to calibrate the camera manually.

4. With the captured image as the background, press **Ctrl + A** on the keyboard to select all the objects on the canvas and drag them to the area where you want to laser engrave and cut. Then, click **Generate G-code and Preview**.

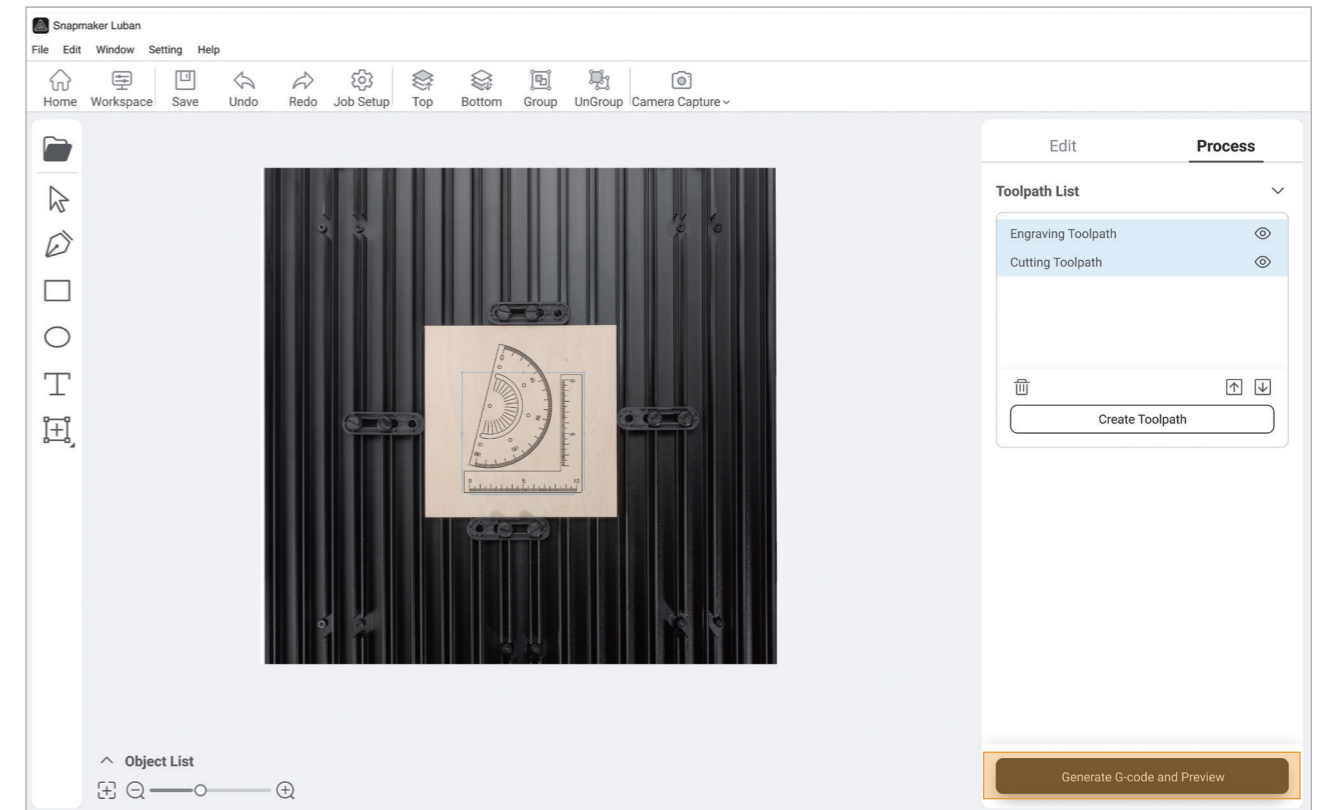

For detailed information about generating G-code files, refer to our online User Manual in Snapmaker Wiki (<https://wiki.snapmaker.com>).

### 3.2.3 Start Your First Job

1. At the bottom-right corner of Luban, click **Export > Load G-code to Workspace**.

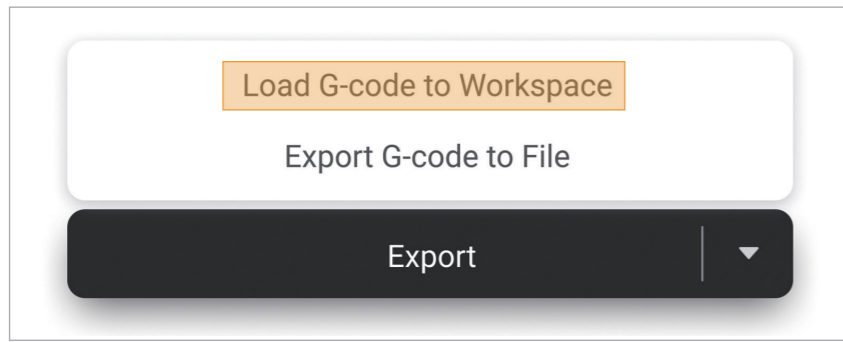

2. In the **Preview** window, click **Start Job > Start on Luban**. In the **Select Mode** window, select **Automatic Thickness Measurement** and click **Start**.

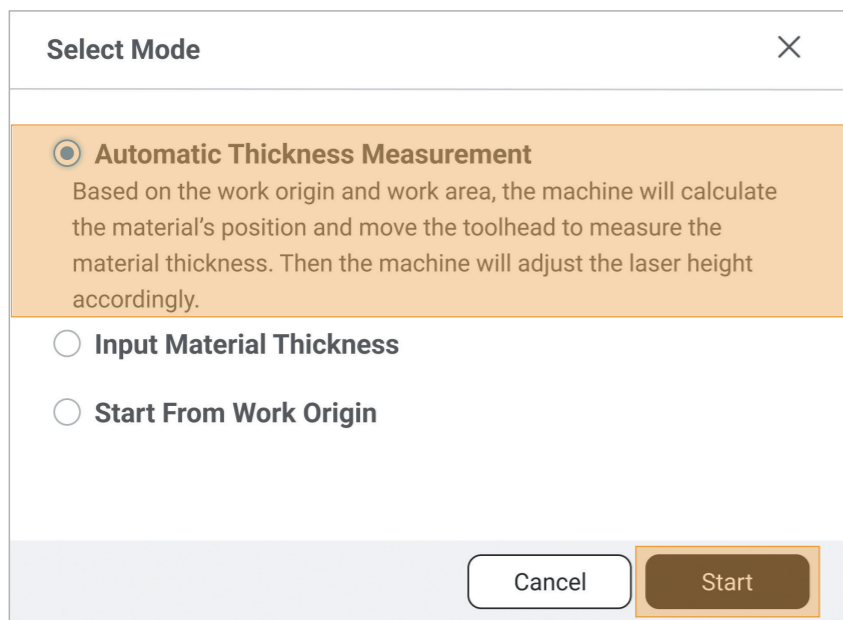

**!** Before you click **Start**, ensure that the Enclosure is correctly assembled and powered on, and that the Enclosure door has been closed.

**!** In case of an emergency, press the emergency stop button on top of the Integrated Controller to stop the printing immediately. After you have handled the emergency, you can release the emergency stop button by rotating it clockwise.

**!** If you use a material with one of the following properties, the thickness measurement may fail.

- The material thickness exceeds 50 mm.
- The material texture is transparent.
- The material surface is glossy or specular.
- The material color is red or black.
- The material is hollow.

Luban provides three laser focusing modes. You are recommended to use **Automatic Thickness Measurement** as instructed by this guide, since this mode is the most convenient one. You can also select other modes based on your needs.

**💡** - **Input Material Thickness:** If the material thickness is known, you can use this mode and enter the material thickness.

- **Start From Work Origin:** To use this mode, you must first manually focus the laser and set the Work Origin. For detailed steps, refer to our online User Manual in Snapmaker Wiki (<https://wiki.snapmaker.com>).

3. After the laser engraving and cutting job is completed, open the Enclosure and take out the finished work.

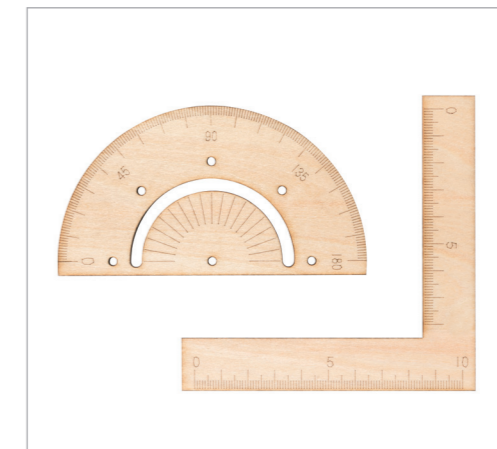



As for the way to determine the laser engraving and cutting position, in addition to the Camera Capture method introduced above, you can also try the Work Origin method.



As for the way to start a laser job, you can also use the USB cable to connect Luban with the machine, or transfer the G-code file to the machine through a USB flash drive or Wi-Fi and start jobs on the Touchscreen.

For more detailed information, refer to our online User Manual in Snapmaker Wiki (<https://wiki.snapmaker.com>).



## Share!

Share your finished work in our Facebook group and our forum.

## 3.3 Maintenance

### Clean the Laser Lens Protector

#### Why

Dust and grease may accumulate on the laser lens protector over time, which will significantly decrease the engraving and cutting capability of the laser. Therefore, you need to clean the laser lens protector to recover the engraving and cutting capability of the module.

#### When

At least once every week.

#### How

1. Prepare the cleaning tools: a cotton swab and the ethyl alcohol (not provided);



The purity of the ethyl alcohol should be at least 75%. The 99% ethyl alcohol works best.

2. Power off the machine and detach the 10W Laser Module from the machine;

3. Moisten a cotton swab with ethyl alcohol, and stick it into the air concentrator hood to wipe the surface of the laser lens protector from center to margin clockwise, until there is no dust, grease, or water.



The cotton swab is a single-use tool. If there is still dust or grease remaining on the laser lens protector after you wipe it once, take a new cotton swab and repeat Step 3 to clean it again.



If the original laser lens protector is damaged, you can replace it with the spare one (included in the package).

For detailed instructions, refer to our online User Manual in Snapmaker Wiki (<https://wiki.snapmaker.com>).

# CNC Carving and Cutting



## 4.1 Preparations

### 4.1.1 Set Up the Machine

1. Turn on the power switch on the back of the Integrated Controller.



To restart your machine, wait for at least 5 seconds after power-off.

2. Follow the on-screen instructions to set up the machine: Read the **Terms and Conditions** > Choose the language > Name the machine > Connect to a Wi-Fi network.

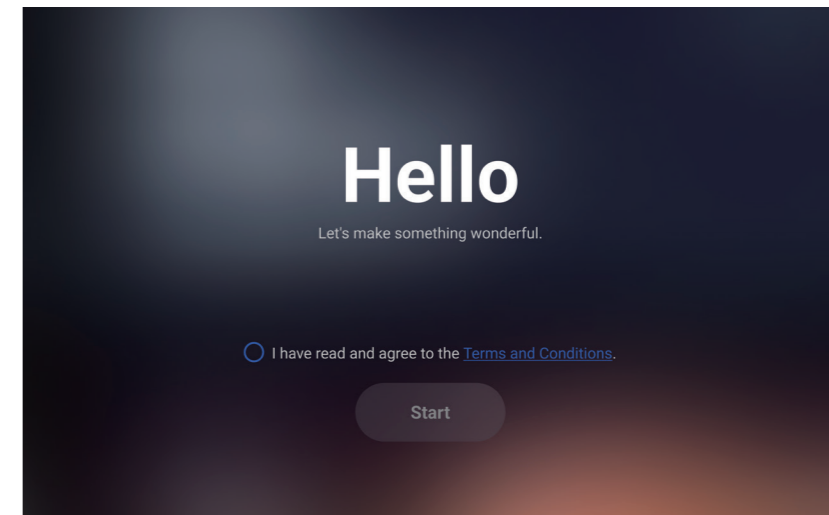

This initial setup wizard appears only the first time you turn on the machine. To change these settings later, tap **Settings** on the Home Screen and select **Wi-Fi**, **Language**, or **About Machine**.

3. Follow the on-screen instructions to get familiar with the basic operations before starting a CNC job.

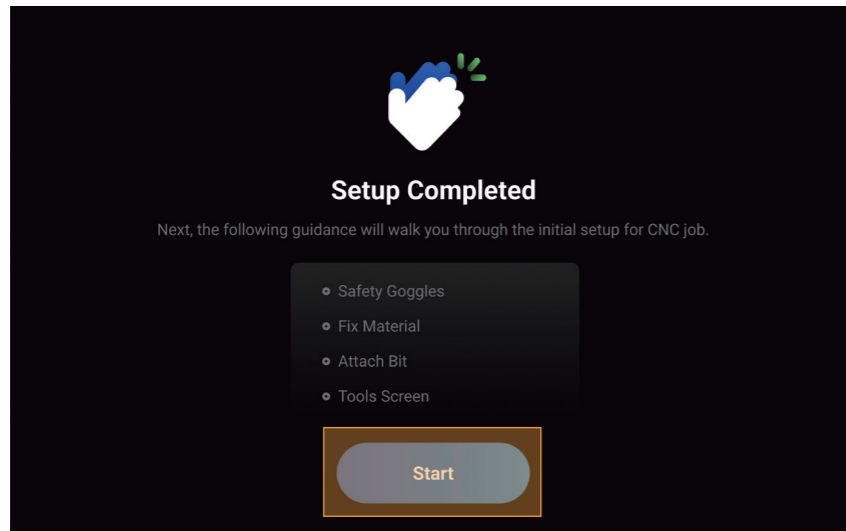

### 4.1.2 Fasten the Material

1. Detach the CNC carving and cutting platform and place the provided HDF sheet on the platform center. Then, assemble the clamp set as illustrated and fasten the material by tightening the star knobs.

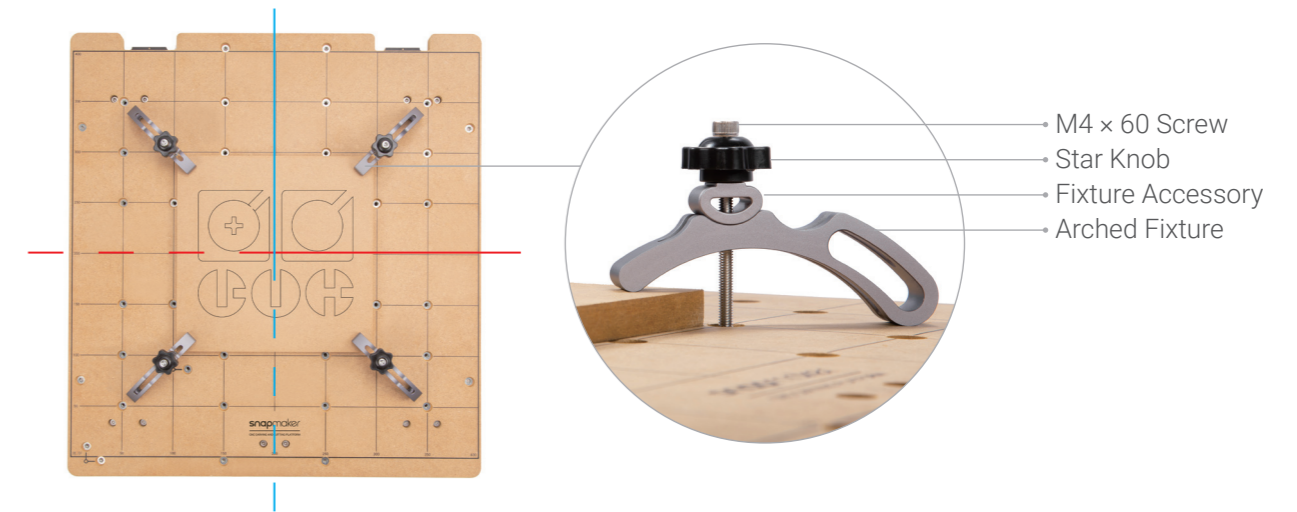

**!** The size of our test model is 152.2 mm x 123.9 mm. **Ensure that the clamp set will not impede the movement of the CNC bit.**

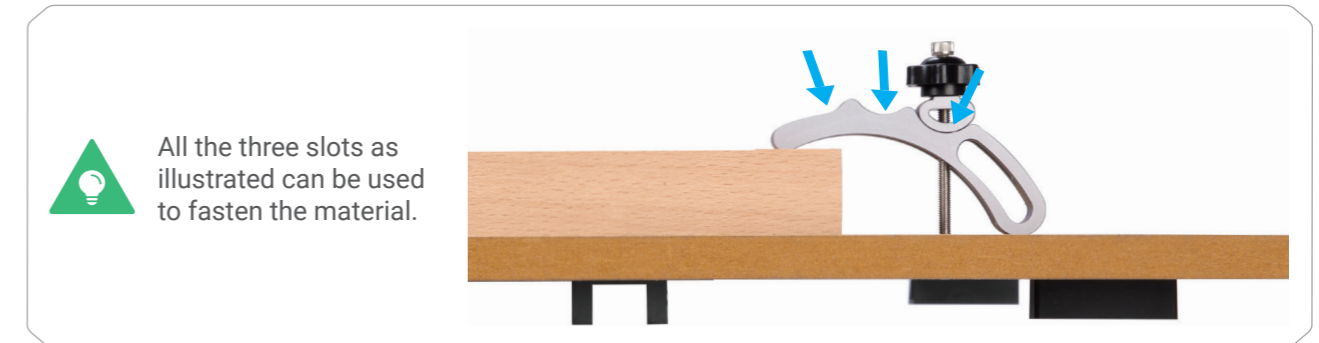

2. Check the positions of the screws to ensure that they are not over-screwed and penetrating the CNC carving and cutting platform.



3. Attach the CNC carving and cutting platform back to the support platform.

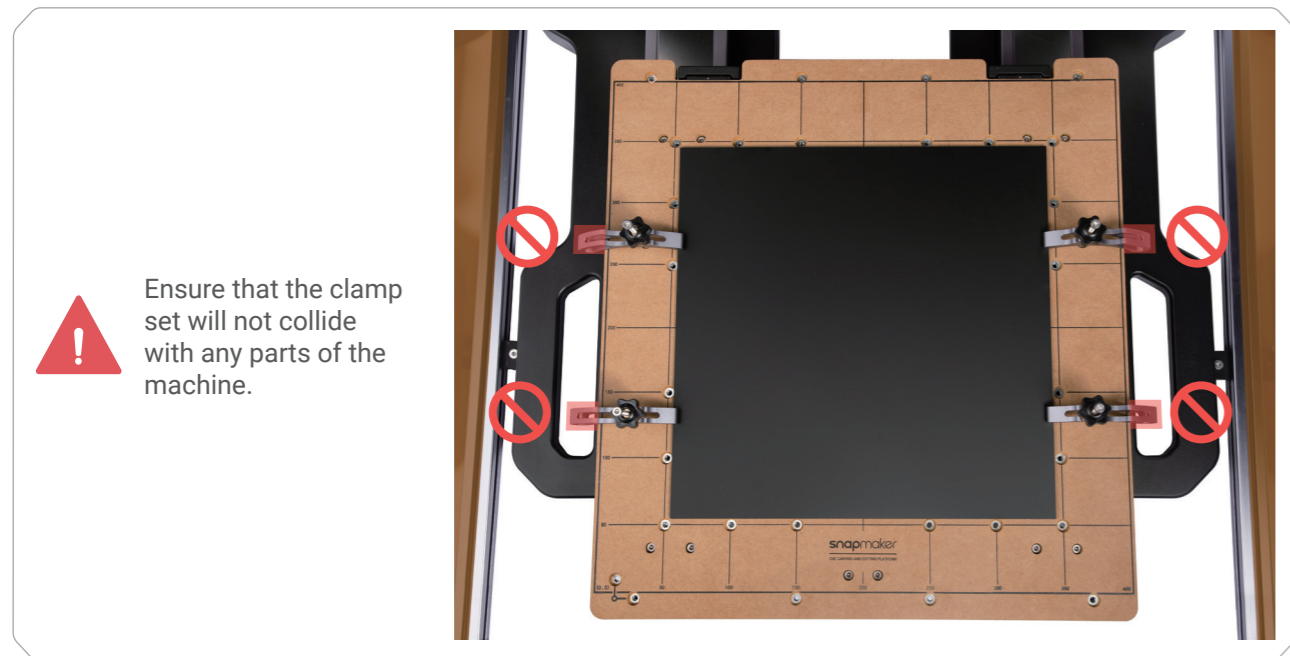

Ensure that the clamp set will not collide with any parts of the machine.

### 4.1.3 Attach the CNC Bit

#### CNC Bit Introduction

##### Flat End Mill (Single-flute) and Flat End Mill (Double-flute)

The flat end mill is typically used for drilling, slotting, or cutting materials into flat surfaces. With a larger flute valley for better chip evacuation, the flat end mill (single-flute) is ideal for machining plastic materials.

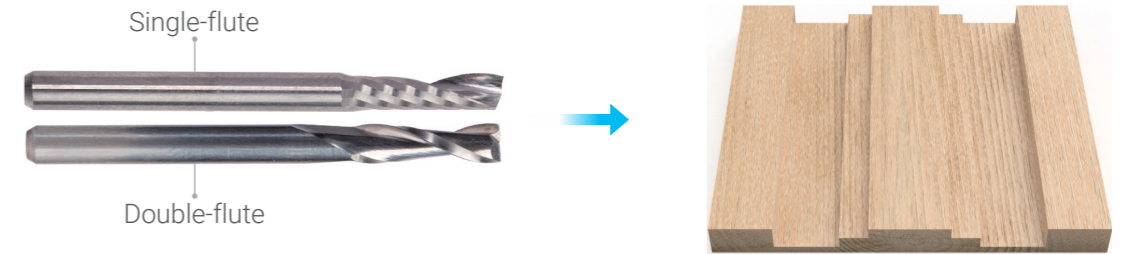

##### Straight Groove V-bit (Double-flute)

The straight groove V-bit (double-flute) is typically used for precision machining, such as relief carving and curved surface milling.

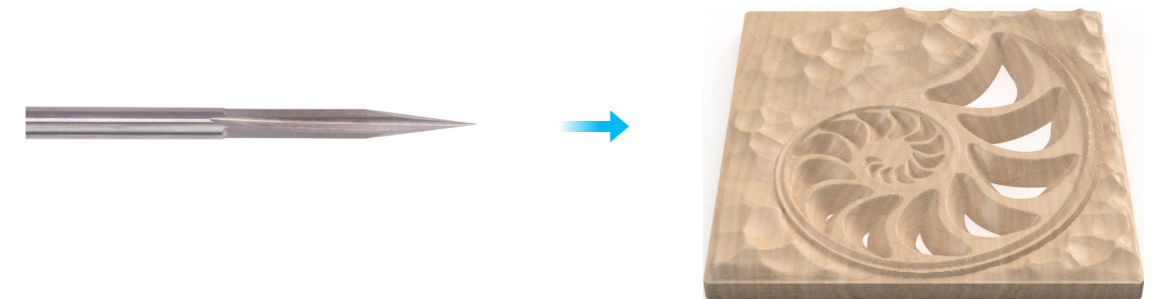

#### How to Attach the CNC Bit

1. Obliquely insert the ER11 collet into the ER11 nut until it snaps into place.

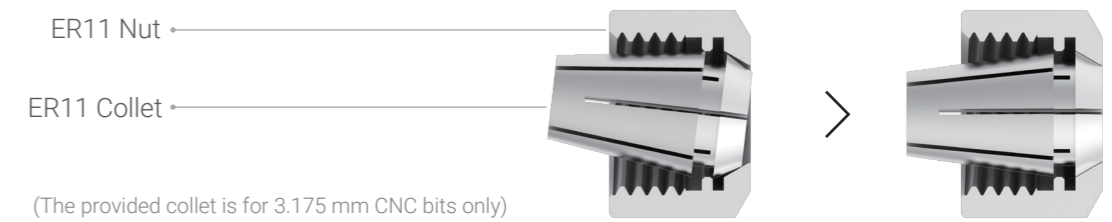

2. First, put on the CNC Safety Goggles. Then, insert the CNC bit into the ER11 collet (**the double-flute flat end mill is required for our test model**) and keep pushing the bit until its end bottoms against the shell of the ER11 collet.

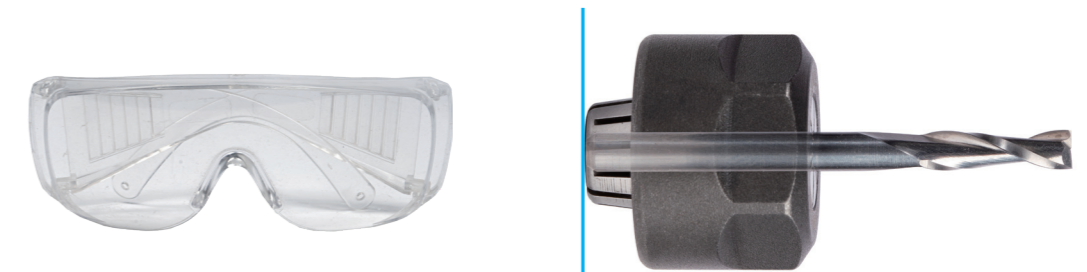

Handle the CNC bits with caution and keep them away from children.

3. Twist the entire unit onto the shank as tight as possible, and then completely tighten the ER11 nut with the open-end wrenches.



14 mm Open-end Wrench

17 mm Open-end Wrench



## Congrats!

You are now ready to carve and cut.

## 4.2 Getting Started

### 4.2.1 Install Snapmaker Luban

1. On the Snapmaker official website, click **Software** in the navigation bar. Then, download and install our tailor-made software Snapmaker Luban (hereafter Luban).

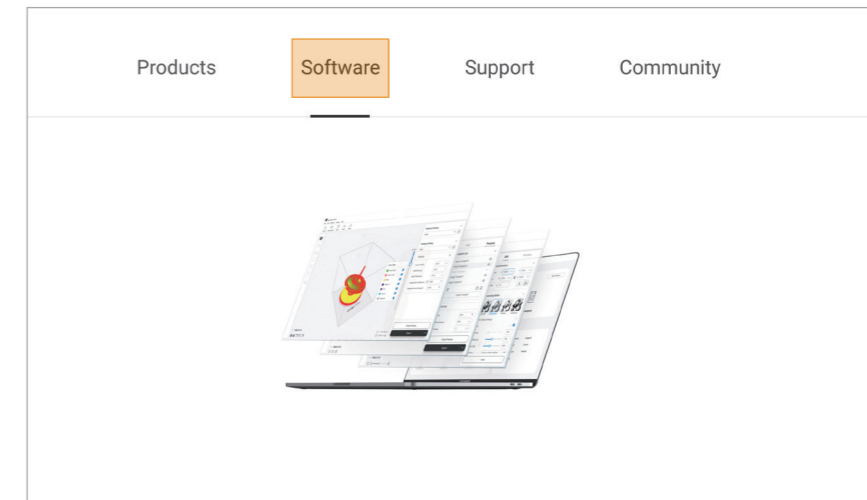

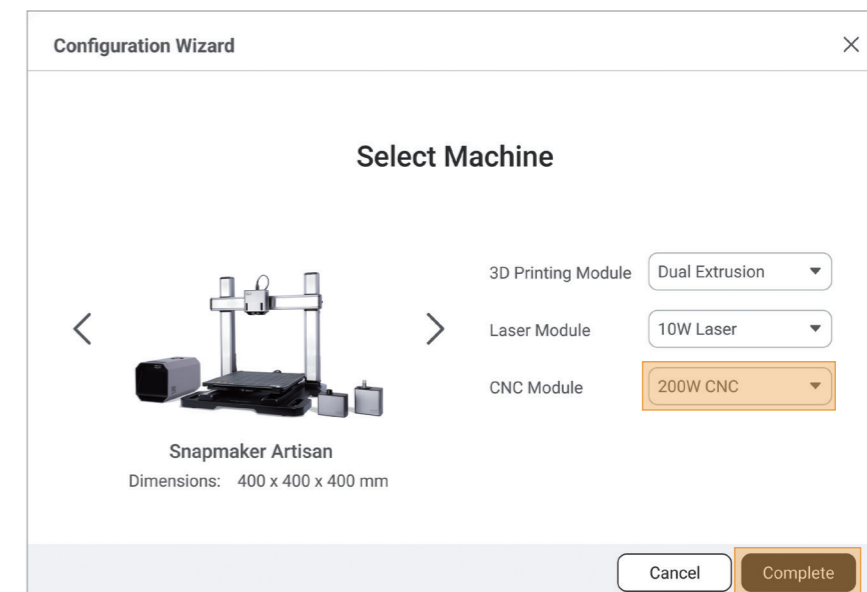

2. Launch Luban, select the language, machine model, and module type, and then click **Complete** to save the settings.



To change these settings later, click **Settings > Preferences** in the menu bar.

3. Ensure that your computer and machine are connected to the same Wi-Fi network, and take the following steps to connect Luban with your machine:

- On the Home page of Luban, click  to enter **Workspace**;
- On the **Connection** panel at the top left corner, click **Wi-Fi**;
- Click , select your machine from the drop-down list, and click **Connect**;
- Tap **Yes** on the Touchscreen to allow the connection.

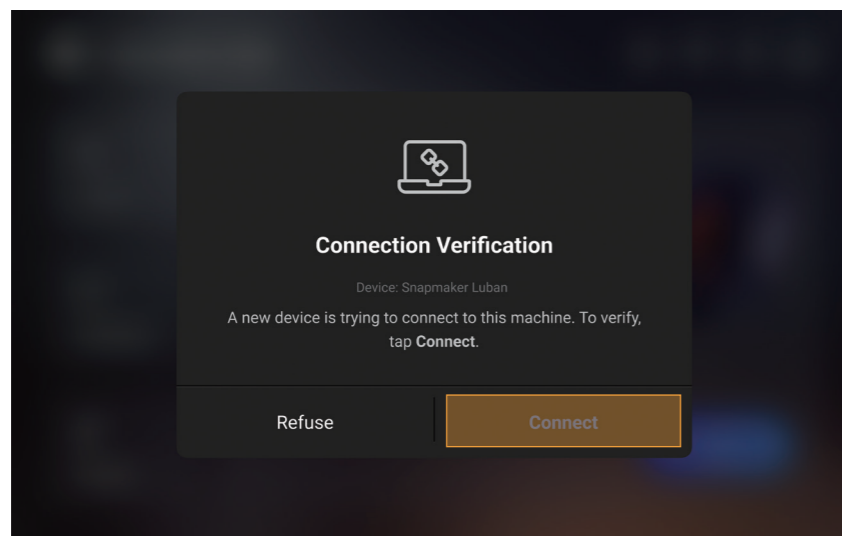
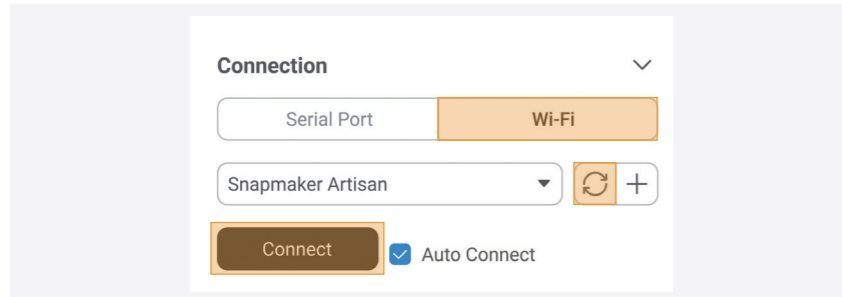
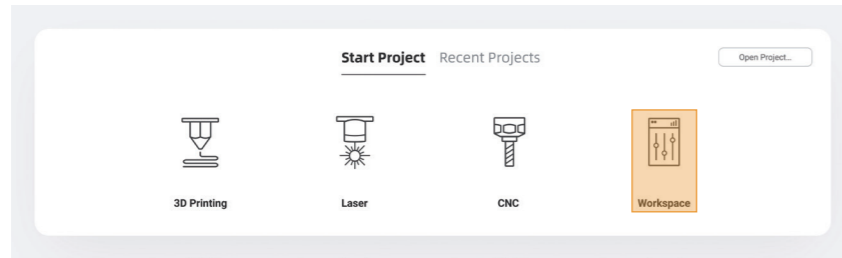

You can also click + and enter the IP address of your machine to manually connect it with Luban. To check the IP address, tap **Settings > About Machine** on the Touchscreen.

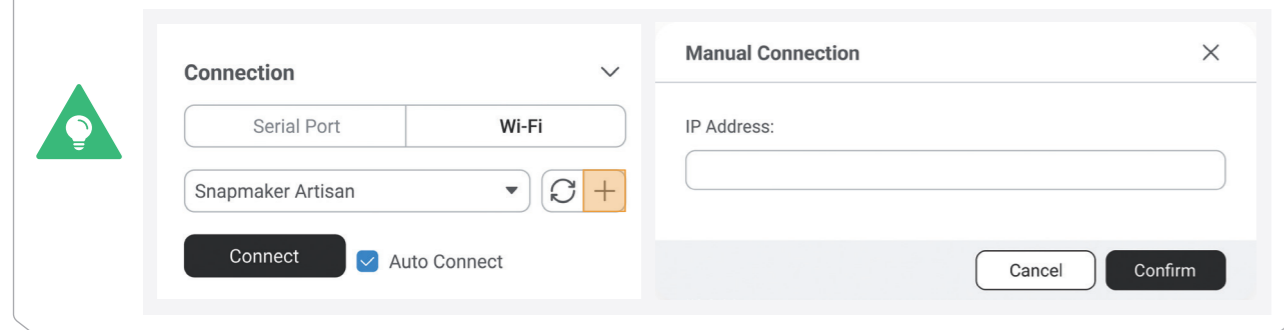

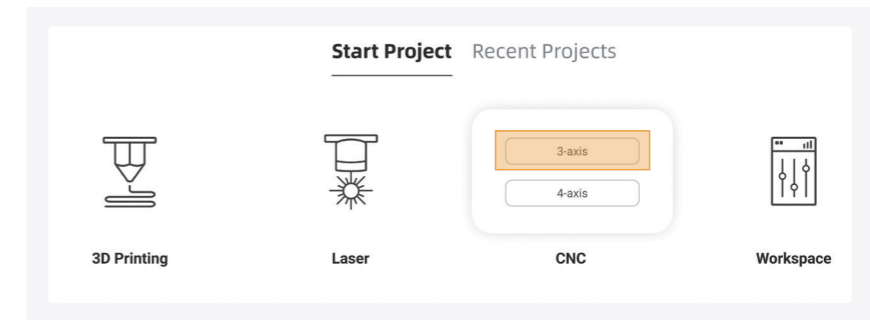

## 4.2.2 Generate the G-code File

1. At the top-left corner of Luban, click **Back** to return to the Home page. Then, click **CNC > 3-axis** to enter the **CNC G-code Generator**.



2. Follow the Beginner's Guide to get familiar with the basic operations. During this process, Luban will automatically load the test model and generate the G-code file.

 If the Beginner's Guide does not pop up or quits unexpectedly, you can click **Help > Beginner's Guide** in the menu bar.

 You can also click  to import your own files and configure the parameters.

3. Click **Export > Load G-code to Workspace**, and then click **Send to Device** on the **G-code Files** panel to send the G-code file to your machine via Wi-Fi.

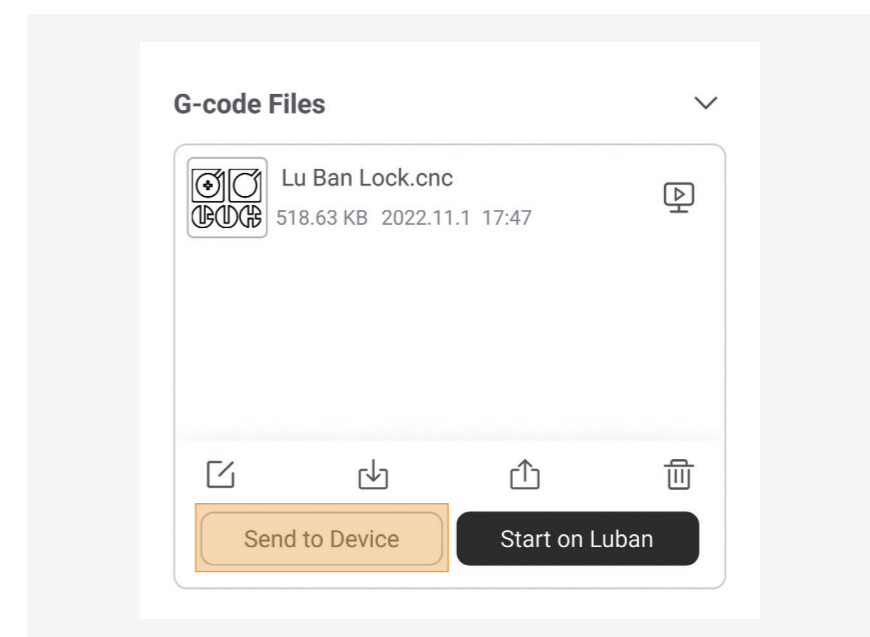
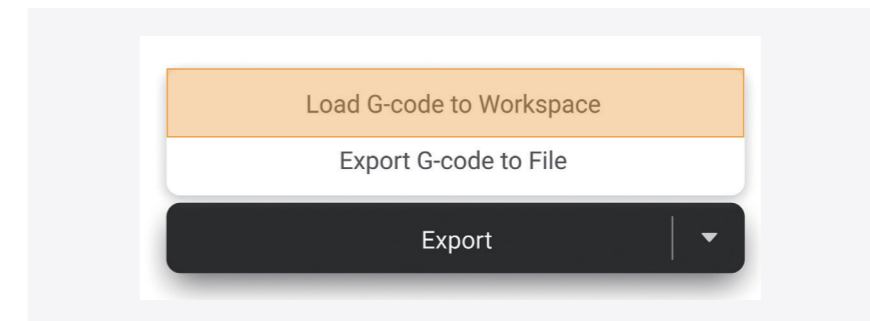



You can also send the G-code file to your machine via the USB flash drive or directly start the job on Luban.

For more detailed information, refer to our online User Manual in Snapmaker Wiki (<https://wiki.snapmaker.com>).

## 4.2.3 Set the Work Origin and Start Carving

### How It Works: Work Origin

Determine where the carving will take place by setting the work origin. The work origin corresponds to the (0, 0) coordinate origin in the software.

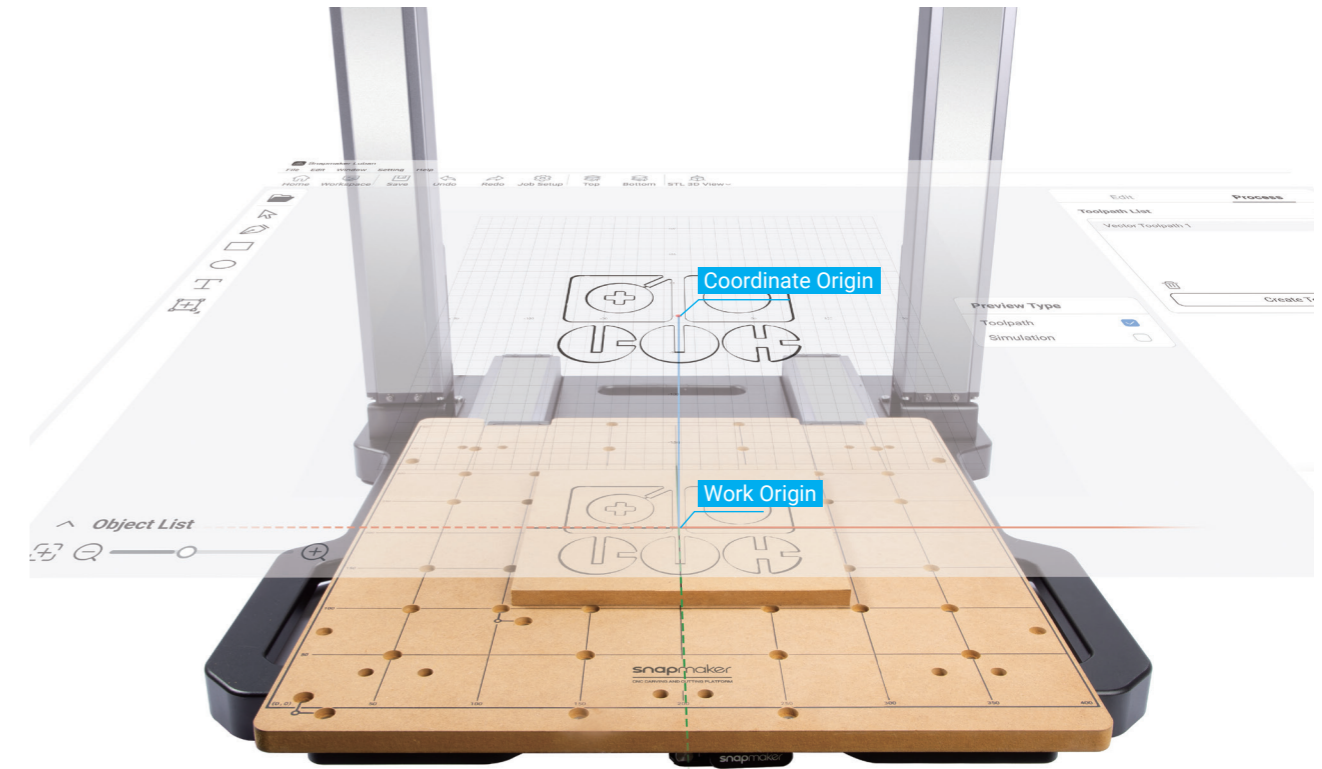

You can also set the work origin using the provided L bracket.

For more detailed information, refer to our online User Manual in Snapmaker Wiki (<https://wiki.snapmaker.com>).

1. After the G-code file is successfully sent to the machine, tap **Start** > **Files** > **Local**, select the received G-code file, and tap **Next**.

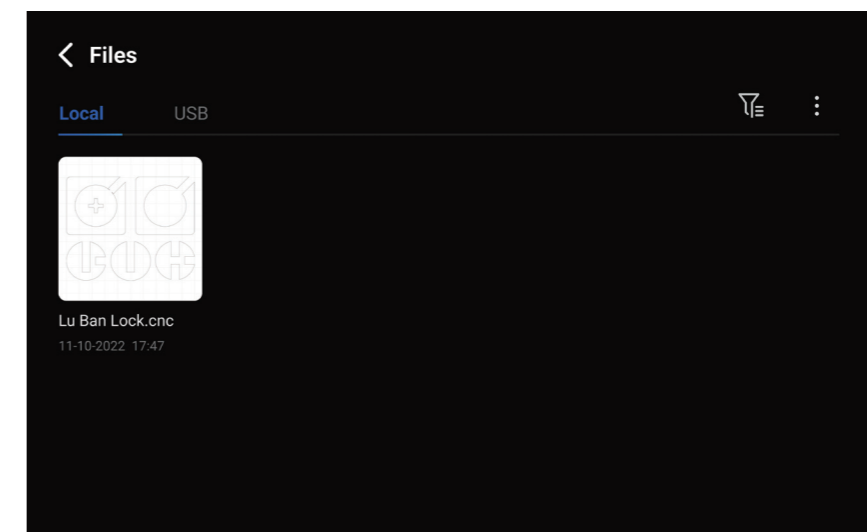

2. Move the CNC bit to where the work origin of the X and Y axes will be (in this case, we set the center of the image as the coordinate origin in the software). For easier observation, you can move the CNC bit closer to the material surface.

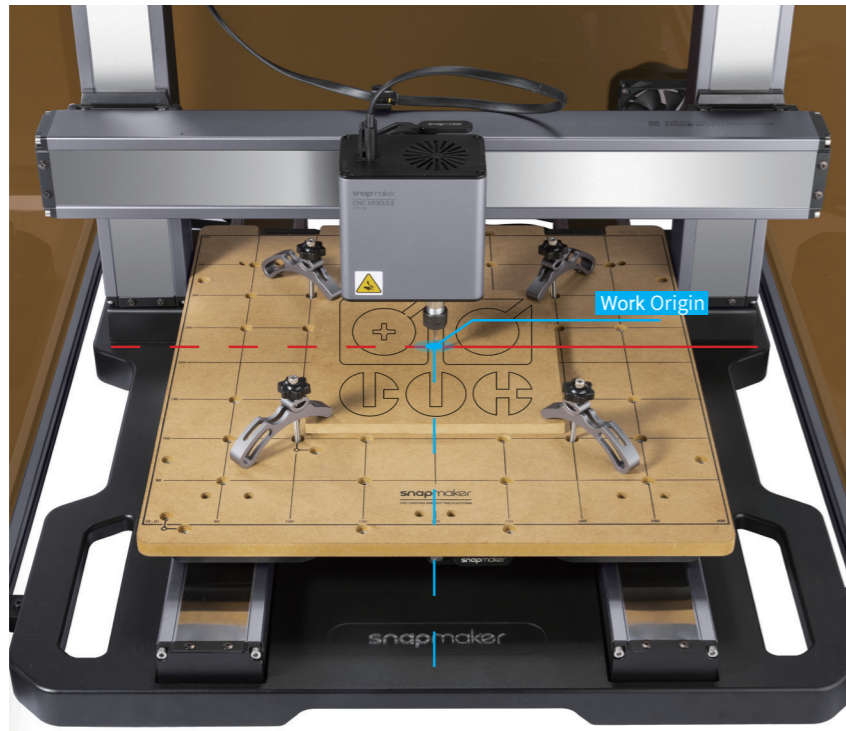
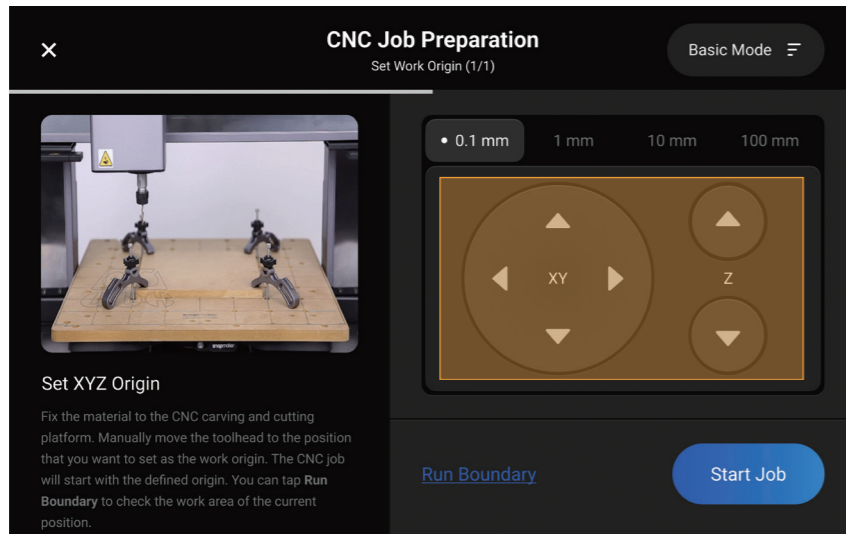

3. Tap **Z+** to lift the CNC bit until it is above the clamp set, and then tap **Run Boundary** to check if the work origin of the X and Y axes is set properly. If any part of the boundary trailed by the CNC bit goes outside of the material, or if the CNC Bit collides with any parts of the machine, reset the work origin of the X and Y axes, and run the boundary again.



**!** If the CNC bit runs into any part of the machine, press the emergency stop button on top of the Integrated Controller. After you have handled the emergency, rotate the emergency stop button clockwise to release it. Change the CNC bit if it is damaged due to the collision.

**💡** If you have run the boundary with the CNC bit above the clamp set, you can lower the CNC bit to run the boundary again to locate the machining area more precisely. **But note:** Always make sure the CNC bit is above the material surface when running the boundary to avoid damaging the bit or the material.

4. Place the calibration card or a piece of A4 paper between the CNC bit and the material. You can set the work origin of the Z axis by tapping the **Z-** or **Z+** button to adjust the height of the CNC bit. If you can feel slight resistance when pulling out the calibration card and wrinkle the card when you push it forward, then the work origin of the Z axis is properly set.

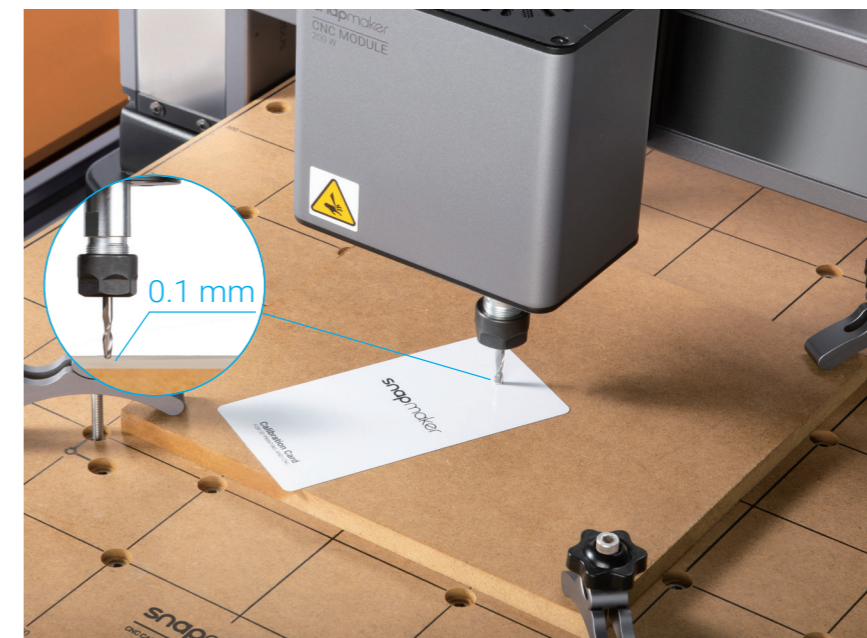





5. In **Basic Mode**, the machine will take the coordinates of where the CNC module currently locates as the coordinates of the work origin. After you have confirmed the work origins of the X, Y, and Z axes are properly set, tap **Start** to start carving.

 Ensure that you place the Integrated Controller within easy reach. In case of an emergency, press the emergency stop button on top of the Integrated Controller to stop the job immediately. After you have handled the emergency, rotate the emergency stop button clockwise to release it.

 It is not recommended to turn on the exhaust fan of the Enclosure during a CNC process, or the dust and wood chips generated will attach to the inner surfaces of the Enclosure and the exhaust fan. For how to disable the exhaust fan, refer to the [Enclosure Settings](#) section of this guide.

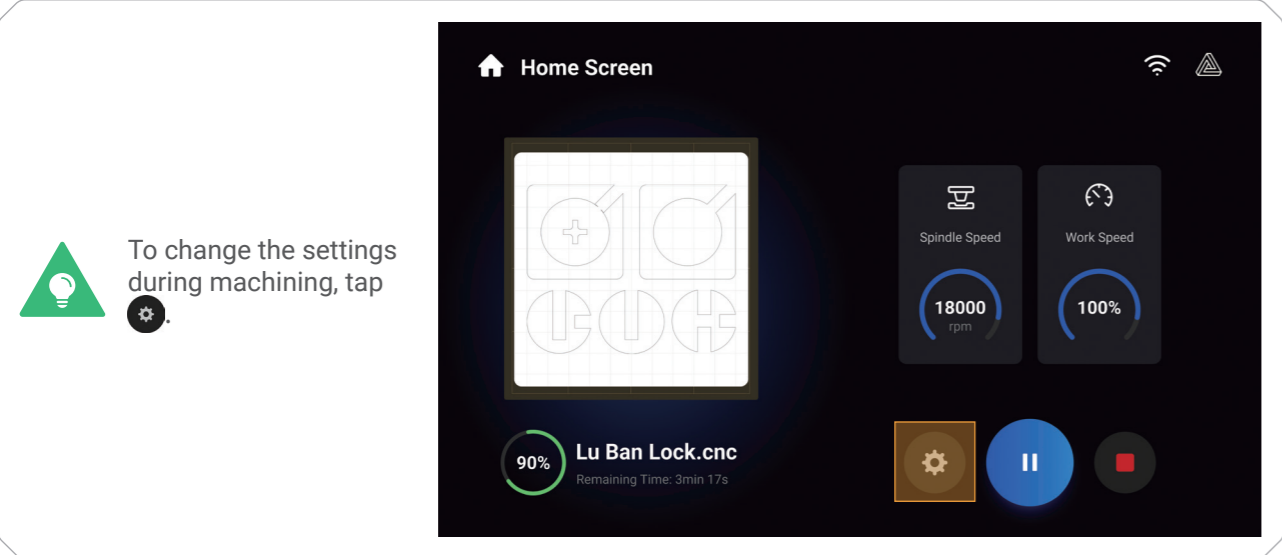

## 4.2.4 Clean the Finished Work and the Machine

1. Remove the clamp set from the CNC carving and cutting platform.



2. Clean the finished work and the machine with a dust collector.



 After each CNC job, you need to clean the dust screen of the CNC Module and the machine surface with a dust collector or cotton swabs. Failure to clean the CNC Module after 150 hours of operation may result in motor dysfunction due to dust accumulation.

 Do NOT rinse the CNC Module with water, and it is also not recommended to wipe the module with alcohol.

3. Remove the finished work with diagonal pliers.

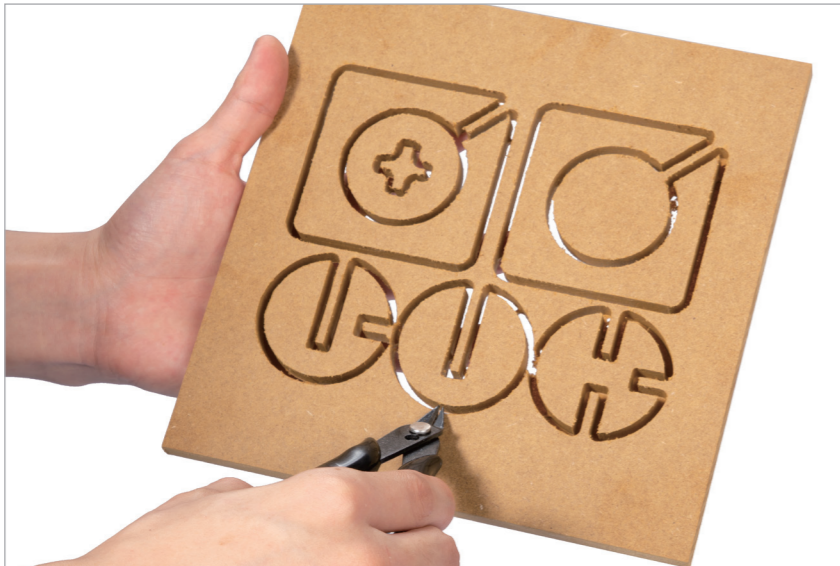

## 4.3 Maintenance

### 4.3.1 Secure the Nut

#### Why

The nut on the CNC carving and cutting platform may fall off after long-time use or under improper operation. When this happens, you need to glue it back.

#### How



Before the operation, wear protective gloves to prevent contact with the toxic AB glue and wear protective equipment to avoid inhaling volatile toxic gases.

1. Prepare the cleaning tools: tweezers, a brush, the AB glue, and protective gloves (the latter three not provided);
2. Clear the sawdust on the nut with the brush;



3. Squeeze out the A glue and B glue in a 1:1 proportion;



Do NOT mistakenly screw the lid of the A glue on the B glue.



### Share!

Share your finished work in our Facebook group and our forum.

4. Mix the A glue with the B glue with the mixing stick, and stir them evenly;



5. Apply the mixed glue to the screw thread of the nut;



6. Tweeze the nut back into the hole of the CNC carving and cutting platform, and press it for a while. Then, wait for at least 24 hours before reuse to ensure that the mixed glue is cured.

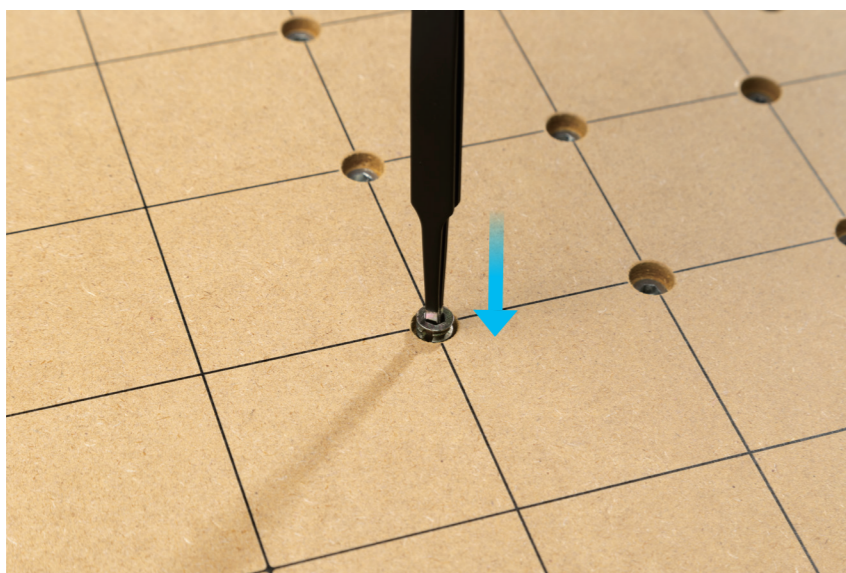

### 4.3.2 Clean the Dust Screen

#### Why

In addition to cleaning the dust screen of the CNC module and the surface of the machine after each operation with a vacuum cleaner, you can also use a cotton swab to clean the dust screen of the CNC module. Failure to clean it effectively may cause the motor of the CNC module to fail due to blockage.

#### When

After every three CNC jobs.

#### How

1. Prepare the cleaning tool: a cotton swab (or tissues) and water;



2. Power off the machine and detach the 200W CNC Module from the machine;

3. Moisten a cotton swab with water and stick it inside the air inlet on top of the module to clean the dust screen until there is no dust or water.



The cotton swab is a single-use tool. If there is still dust remaining on the dust screen after you wipe it once, take a new cotton swab and repeat Step 3 to clean it again.

# Resources

You can learn more about the usage, maintenance, and troubleshooting of your printer in Snapmaker Wiki:  
<https://wiki.snapmaker.com>

We are here for you whenever you need support:  
<https://support.snapmaker.com>

For any sales inquiries:  
[sales@snapmaker.com](mailto:sales@snapmaker.com)

For product purchases:  
<https://shop.snapmaker.com>

Share anything you want with other Snapmaker users in our forum:  
<https://forum.snapmaker.com>

